

CUTE 12/30X

User Manual



Warning

The improper operation may destroy the structure of the product and lead to abnormal operation of the camera. Please pay attention to the following operations.

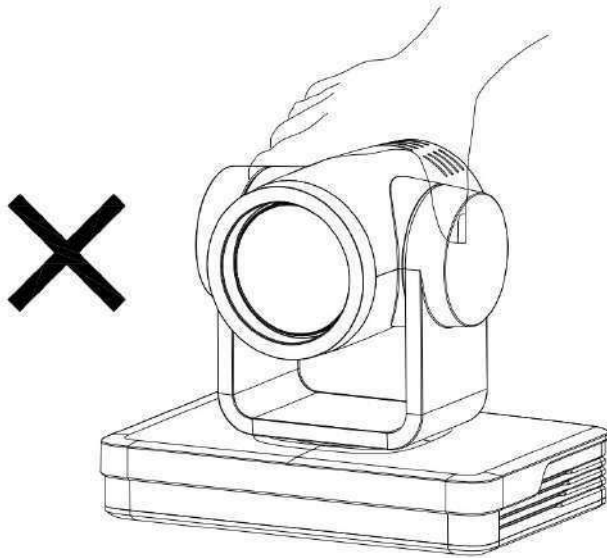

 Do not grasp the lens barrel with your hand while moving the camera;

 Move the camera by holding the bottom with both hands or one hand.

Whether electrified or not, do not shake the lens and the platform by hand, otherwise it may damage the platform, resulting in abnormal self-examination of the camera, unable to start normally.

 Whether

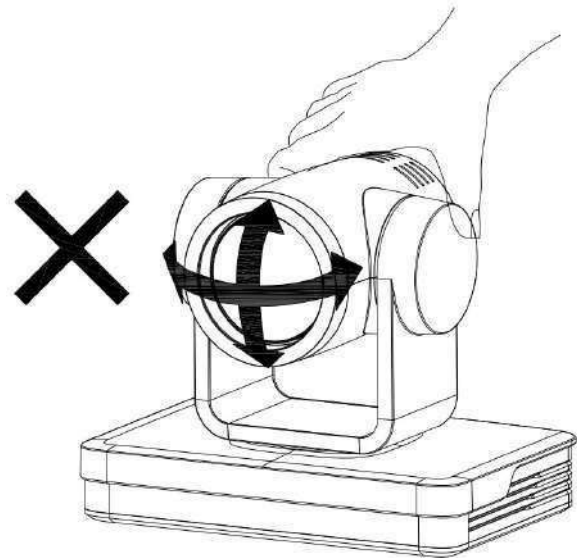

Attentions

This manual describes in detail the functions, installation and operation principles and methods of the product. Before installing and using this product, please read it carefully.

1. Use Attention

- ★ During transportation, storage, installation and use, it is necessary to prevent heavy pressure, severe vibration and immersion so as to avoid damage to products.
- ★ The product shell is made of organic material. It is strictly forbidden to contact with corroded liquid, gas or solid substances.
- ★ Don't let the product get wet or rained. Don't use it beyond the limit of temperature and humidity.
- ★ When cleaning equipment lens, please use dry soft cloth to wipe. When dirt is serious, please use neutral cleaner to wipe gently.
- ★ Do not use strong or corrosive detergents to avoid scratching the lens and affecting the image effect.
- ★ This product has no parts that users can repair by themselves, and the damage caused by users' self-disassembly does not fall within the scope of warranty.

2. Electrical safety

- ★ The installation and use of products must strictly comply with the national and local electrical safety standards.
- ★ Do not use power adapters beyond the specifications of the power supply, otherwise the equipment components will burn out and will not work properly.
- ★ In the process of using the product, we should keep enough distance from the high-power equipment, and do a good job of lightning protection, surge protection and other protective measures when necessary.
- ★ When the product is not in use, please disconnect the power and disconnect the power adapter from the power socket.
- ★ The product uses DC 12V power supply, and the polarity of power plug is as shown in the right picture.



3. Careful installation

- ★ Do not rotate the cylinder of the product by hand, otherwise it will destroy the rotating shaft of the structure or cause abnormal work of the signal line.
- ★ Installation and placement of equipment should be horizontal and stable, and the product should not be tilted, otherwise the picture may be skewed.
- ★ Installation ensures that there are no obstacles in the rotating range of the platform to prevent damage to the rotating shaft of the structure.
- ★ Do not turn on power until all installation work is completed.

4. Magnetic Interference

- ★ The electromagnetic field at a specific frequency may affect the local image. The product is Class A product. Radio interference may occur in the home environment, and users need to take appropriate measures.

Content

1. FAST INSTALLATION	- 4 -
1.1 PRODUCT INTRODUCTION.....	- 4 -
2. PRODUCT OVERVIEW.....	- 5 -
2.1 DIMENSION	- 5 -
2.2 ACCESSORY.....	- 5 -
2.3 RS-232 INTERFACE	- 6 -
2.4 MAIN FEATURES.....	- 7 -
2.5 TECHNICAL SPECIFICATION	- 8 -
3. REMOTE CONTROLLER	- 10 -
3.1 CODING OF WIRELESS REMOTE CONTROLLER.....	- 10 -
3.2 KEYS INSTRUCTION.....	- 11 -
3.3 MENU INTRODUCTION.....	- 13 -
4. NETWORK CONNECTION	- 15 -
4.1. NETWORK CONNECTION	- 15 -
4.2 INTERNET EXPLORER LOG IN	- 17 -
5. SERIAL COMMUNICATION CONTROL.....	- 18 -
5.1 VISCA PROTOCOL LIST	- 18 -
5.1.1 Camera return command.....	- 18 -
5.1.2 Camera control command	- 18 -
5.1.3 Inquiry command.....	- 21 -
5.2 PELCO-D PROTOCOL COMMAND LIST	- 23 -
5.3 PELCO-P PROTOCOL COMMAND LIST	- 24 -
6. MAINTENANCE AND TROUBLESHOOTING	- 25 -
6.1. PRODUCT MAINTENANCE	- 25 -
6.2 TROUBLESHOOTING.....	- 25 -
COPYRIGHT	- 26 -

1. Fast Installation

1.1 Product introduction

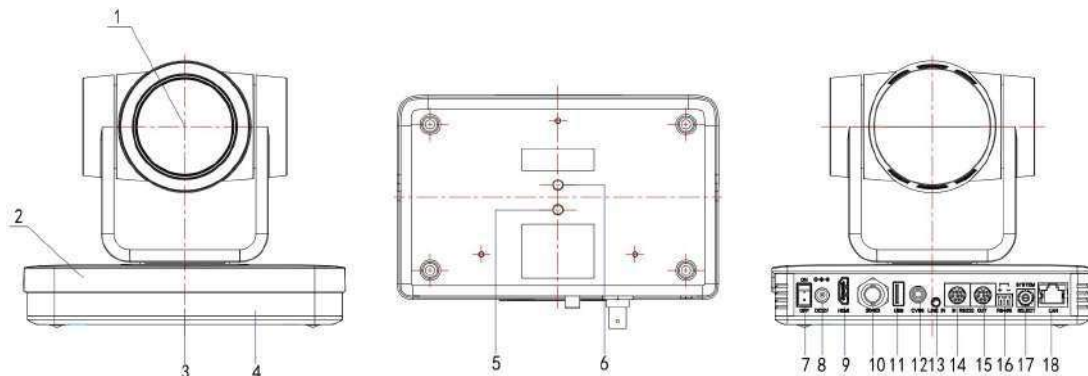

Picture 1.1 Interface

Interface specification:

- | | | |
|-----------------------|---------------------------------------|---|
| 1. Lens | 7. Power Switch Key | 13. Audio Input Interface (Line-IN) |
| 2. Camera Base | 8. Power input socket (DC12V) | 14. RS232 Input Interface |
| 3. Remote Controller | 9. HDMI Output Interface | 15. RS232 Output Interface |
| Receiver Light | | |
| 4. Infrared reception | | 16. RS485 input interface (left plus right minus) |
| 5. Tripod Screw Hole | 11. USB2.0 Interface (U Disk Storage) | 17. Rotary dial switch |
| 6. Tripod Screw Hole | 12. CVBS Output Interface | 18. Network LAN Interface |

2. Product overview

2.1 Dimension

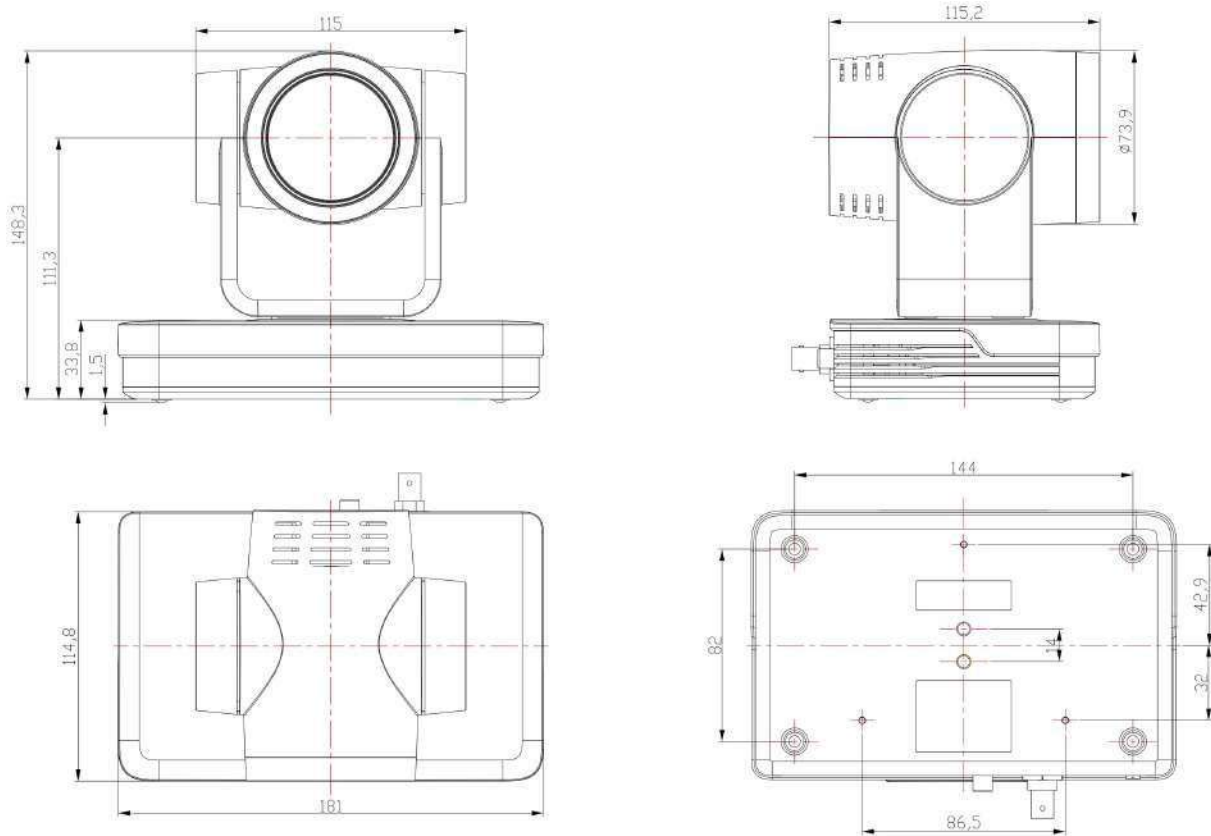

Figure 2.1 Camera dimension

2.2 Accessory

When you unpack, check that all the supplied accessories are included:

Configuration	Standard	Optional
Accessory	Power adapter 1piece	IR Remote controller 1 piece
	USB3.0 Cable (U3 Model)	WR Remote controller 1 piece
	RS232 Cable	Wall mounting bracket
	User manual 1	Upside-down mounting bracket
	Double-side glue shim	
	Warranty card 1 piece	

2.3 RS-232 Interface

1) RS-232 interface

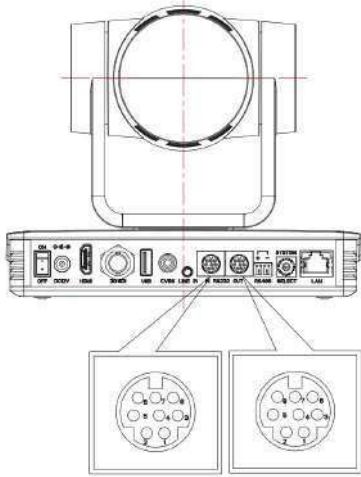

Computer or Control Keyboard and Product Connection Method

Product	WindowsDB-9
1. DTR	1. DCD
2. DSR	2. RXD
3. TXD	3. TXD
4. GND	4. DTR
5. RXD	5. GND
6. GND	6. DSR
7. IR OUT	7. RTS
8. NC	8. CTS
	9. RI

2) Mini-DIN8-pin Port

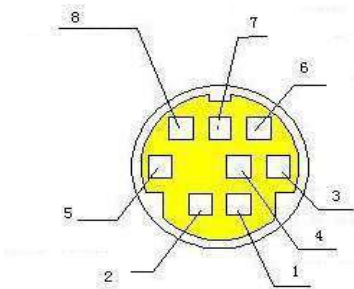

NO.	Port	Definition
1	DTR	Data Terminal Ready
2	DSR	Data Set Ready
3	TXD	Transmit Data
4	GND	Signal ground
5	RXD	Receive Data
6	GND	Signal ground
7	IR OUT	IR Commander Signal
8	NC	No Connection

3) RS232(DB9)Port

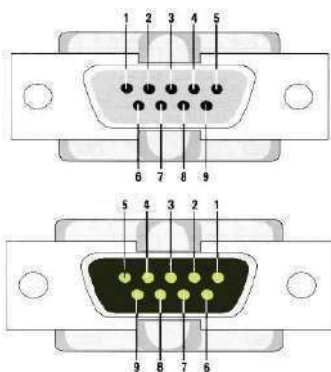

NO.	Port	Definition
1	DCD	Data Carrier Detect
2	RXD	Receive Data
3	TXD	Transmit Data
4	DTR	Data Terminal Ready
5	GND	System Ground
6	DSR	Data Set Ready
7	RTS	Request to Send
8	CTS	Clear to Send
9	RI	Ring Indicator

4) ISCA networking mode is as follows:

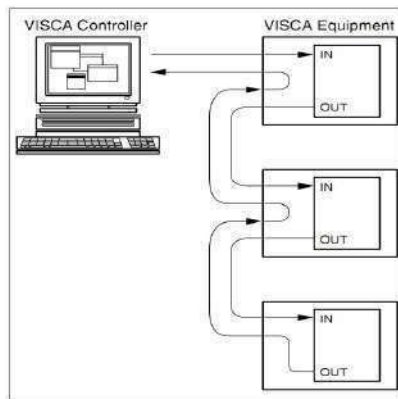

Product Cascade Connection Method

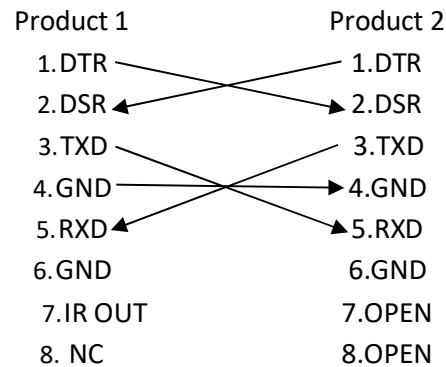

Note: The product has RS232 input and output interface, which can be cascaded in the above way.

2.4 Main Features

This series camera offers perfect functions, superior performance and rich interfaces. The features include advanced ISP processing algorithms to provide vivid images with a strong sense of depth, high resolution and fantastic color rendition. It supports H.265/H.264 encoding which makes motion video fluent and clear even with less than ideal bandwidth conditions.

1. **Superb High-definition Image:** It employs 1/2.8 inch high quality CMOS sensor. Resolution is up to 1920x1080 with frame rate up to 60 fps.
2. **Various Optical Zoom Lens:** It has 5X/10X/12X/20X/30X optical zoom lens for options. The 5X zoom lens is with 83.7 ° wide view angle without distortion.
3. **Leading Auto Focus Technology:** Leading auto focus algorithm makes lens a fast, accurate and stable auto-focusing.
4. **Low Noise and High SNR:** Low Noise CMOS effectively ensure high SNR of camera video. Advanced 2D/3D noise reduction technology is also used to further reduce the noise, while ensuring image sharpness.
5. **Multi-Format Video Outputs:** support HDMI、LAN interfaces; HDMI、LAN interfaces support audio and video output simultaneously.
6. **Multiple Video compression:** Support H.265/H.264 video compression; Supports video compression up to 1920 x 1080 resolution 60 frames/seconds. Support AAC, MP3, G. 711A audio compression, support 8000, 16000, 32000, 44100, 48000 sampling frequency.
7. **Audio and video storage:** USB2.0 interface supports U disk storage function, real-time recording and storage
8. **Built-in gravity sensor:** Built-in gravity sensor, supporting the automatic overturn function of the platform, convenient for engineering installation.

9. **Multiple Network Protocol:** Support ONVIF, GB/T28181RTSP, RTMP protocols and support RTMP push mode, easy to link streaming media server (Wowza, FMS); Support RTP multicast mode, support network full command VISCA control protocol.

9. Control interface: RS485, RS232; RS232 support cascade, easy to install and use.

10. **Multiple Control Protocols:** Support VISCA, Pelco-D, Pelco-P and support auto-recognize protocol.

11. Silent platform: High precision stepping motor and precise motor drive controller are used to ensure stable operation and no noise.

12. **Low-power sleep function:** Support low-power sleep/wake up, the consumption is lower than 400mW under sleep mode

13. **255 Presets Positions:** Up to 255 presets (10 presets by remoter).

14. Various remote controllers: Users can choose infrared or wireless remote controllers according to the environmental conditions used. 2.4G wireless remote controller is not affected by angle, distance and infrared interference. Support remote control signal transmission function, convenient for the use of back-end equipment.

15. **Wide Application:** Tele-education, Lecture capture, Webcasting, Videoconferencing, Tele-training, Tele-medicine, Interrogation and Emergency command systems.

2.5 Technical Specification

Model	CUTE 12X
Camera Parameter	
Optical Zoom	12X f=3.9~46.8mm
Sensor	1/2.8 inch high quality HD CMOS sensor
Effective Pixels	16: 9, 2.07 megapixel
Video Format	HDMI video format 1080P60/50/30/25/59.94/29.97, 1080I60/50/59.94, 720P60/50/30/25/59.94/29.97 CVBS output: 570i 480i USB3.0 interface video format: 1920X1080@60fps Max
View Angle	6.3° (tele) 72.5° (wide)
AV	F1.8 – F2.4
Digital Zoom	10X
Minimum Illumination	0.5Lux (F1.8, AGC ON)
DNR	2D & 3D DNR
White Balance	Auto / Manual/ One Push/ 3000K/3500K/4000K/4500K/5000K/5500K/6000K/6500K/7000K
Focus/Aperture/ Electronic Shutter	Auto/Manual/One Push Focus
Iris	Auto/Manual
Shutter	Auto/Manual
BLC	ON/OFF
WDR	OFF/ Dynamic level adjustment
Video Adjustment	Brightness, Color, Saturation, Contrast, Sharpness, B/W mode, Gamma curve
SNR	>55dB

Input/Output Interface	
Video Output	HDMI, LAN PoE, USB3.0
Video Stream	Dual stream output
Video Compression Format	LAN Interface: H.265, H.264, Dual stream output USB3.0 Interface: YUV
Audio Input Interface	Double track 3.5mm linear input
Audio Output Interface	HDMI, LAN
Audio Compression Format	AAC/MP3/G.711A
Network Protocol	RTSP, RTMP, ONVIF, GB/T28181, Support network VISCA control protocol Support remote upgrade, remote restart, remote reset
Control Interface	RS232, RS485
Control Protocol	VISCA/Pelco-D/Pelco-P, Baud Rate: 115200/9600/4800/2400bps
Power Interface	HEC3800 outlet (DC12V)
Input Voltage	DC12V \pm 10%
Input Electric Current	Maximum: 1A
Power Consumption	Maximum: 12W
PTZ Parameter	
Pan/Tilt Rotation	$\pm 170^\circ$, $-30^\circ \sim +90^\circ$
Pan Control Speed	0.1 $-60^\circ/\text{sec}$
Tilt Control Speed	0.1 $-30^\circ/\text{sec}$
Preset Speed	Pan: $60^\circ/\text{sec}$, Tilt: $30^\circ/\text{sec}$
Preset Number	255 presets (10 presets by remote controller)
Other Parameter	
Stored Temperature	$-10^\circ\text{C} \sim +60^\circ\text{C}$
Storage Humidity	20%~95%
Working Temperature	$-10^\circ\text{C} \sim +50^\circ\text{C}$
Working Humidity	20%~80%
Dimension	178mmX115.5mmX150.9mm
Weight	1.38KG
Attachment	
Package	12V/1.5A Power supply, RS232 control cable, USB3.0 connection cable(U3 model), USB2.0 connection cable(U2 model), Remote Controller, Manual, Warranty Card
Accessories Optional	Mount (Extra Cost)

3. Remote Controller

Instructions for the application of remote controllers: Remote controllers are divided into two types: infrared remote controllers and wireless remote controllers. Please read the following according to the actual type of remote controllers.

3.1 Coding of Wireless Remote Controller

Wireless remote control: The steps of using, code checking and code clearing are as follows.



A single pair of one-to-one codes

Press the "Set" button + "*" button for 3 seconds and the LED lights will blink continuously after the key is released. The receiving end will power on and the LED will be extinguished if the code is successfully matched. The product can only be controlled by this remote controller after the code is matched alone. If other remote controllers need this remote controller to clear the code, or the new remote controller can re-code. If the alignment is unsuccessful, the red LED lights flicker for 20 seconds and then go to sleep. At this time, press any key to wake up and re-align.

Note: After successful code alignment, you need to choose the camera address to be controllable.

Clear the code data

Press the "Setup" button + "" button LED lamp flickers from off to on, the receiver power off and power on again, and the LED extinction indicates the successful removal of the code data.

Sleep and wake-up

When working, no operation immediately enters the sleep mode and wakes up by pressing any key. The keys of infrared remote controller and wireless remote controller are the same.

3.2 Keys Instruction

After the product starts normally, it receives the infrared command and executes it. Press the key of the remote control. The remote control receives the green flashing of the indicator lamp. Release the key and stop the flashing of the indicator lamp. Infrared remote control can be used for preset setting, positioning, horizontal, pitch rotation and other operations.

1) The key-press mode mentioned in this manual refers to the two actions of pressing and relaxing the keys on the remote controller. For example, "press the [HOME] key" refers to the action of pressing the [HOME] key and then relaxing. If it takes a long time to press the key, it will be specified in the manual.

2) When the combination keys need to be operated according to the instructions, they are operated in the order of the instructions. For example, "press the [*]+ [#]+ [F1] key" means first press the [*] key, then press [#], and finally press the [F1] key.

1. Address selection



Select the camera address to control.

2. Standby Key

After 3S long press, the camera will step into standby mode. Long press 3S again, the camera will self-test again and back to HOME position. (Note: If power-on mode is turned on and Preset 0 is set, and there is no operation within 12s, it will automatically point to the specified preset position)

3. Focus Control Key



【Auto Focus】 : Enter into auto focus mode.

【Manual Focus】 : Enter into manual mode;

【Focus+】 : focal length (Effective only in manual focusing mode)

【Focus-】 : Focal distance (Effective only in manual focusing mode)

If these two keys are pressed for a long time, they will continue to pull closer/farther and stop when they are released.

4. Zoom Control Key



【zoom+】 : Close the picture and increase the lens multiples

【zoom-】 : Scene widening and lens multiples narrowing
If these two keys are pressed for a long time, they will continue to pull closer/farther and stop when they are

released.

5. Set or Clear Preset key



Set Preset: Set preset key + 0-9 number key:
Note: Up to 10 presets can be set by remote control.

Call preset: Set preset key + 0-9 number key.
Note: If the number key is not preset, it is invalid.

Clear Preset key: Press [clear the preset] first, then press one of the numeric keys 0 - 9, then cancel the corresponding preset.

Note: Press the key three times in a row to cancel all presets.

6. Pan/Tilt Control Key



Press ▲ Key :Up Press ▼ Key :Down
Press ◀ Key :Lef Press ▶ Key :Right

“HOME” Key: Return to the middle position or enter into the next level menu

Up and down left and right key: control the top and bottom left and right rotation of the platform; long press the top and bottom left and right rotation button, the platform from slow to fast continuous rotation until the end of the journey position; halfway release stop rotation.

【HOME】: The platform goes back to the middle or into the next menu.

7. Menu Setting



【HOME】 : Open or close the OSD menu, or Enter / exit the OSD menu or return to the previous menu.

【HOME】 : The PTZ goes back to the middle, decides to modify, or enters the next menu.

【 ↑ 】 【 ↓ 】 : Select controls

【 ← 】 【 → 】 : Modify parameter values

【 Backlight on/off 】 : Backlight on /off

8. Remote Controller Address Settings

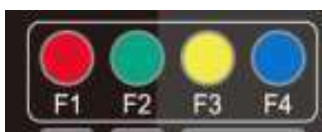

【 * 】 + 【 # 】 + 【 F1 】 : Set Address No. 1

【 * 】 + 【 # 】 + 【 F2 】 : Set Address No. 2

【 * 】 + 【 # 】 + 【 F3 】 : Set Address No. 3

【 * 】 + 【 # 】 + 【 F4 】 : Set Address No. 4

9. Combination key function

【 # 】 + 【 # 】 + 【 # 】 : Cancel all presets

【 # 】 + 【 # 】 + 【 0 】 : Switching Video Format 1080P60

【*】+【#】+【6】： Restore Factory Defaults	【#】+【#】+【1】： Switching Video Format 1080P50
【*】+【#】+【3】： The menu is set in Chinese	【#】+【#】+【2】： Switching Video Format 1080I60
【*】+【#】+【4】： The menu is set in English	【#】+【#】+【3】： Switching Video Format 1080I50
【*】+【#】+【9】： Switching Forward and Flip	【#】+【#】+【4】： Switching Video Format 720P60
【*】+【#】+Auto： Entering the Aging Model	【#】+【#】+【5】： Switching Video Format 720P50
【#】+【*】+Auto： Stop aging mode	【#】+【#】+【6】： Switching Video Format 1080P30
【*】+【#】+Manual： IP, User name, Password	【#】+【#】+【7】： Switching Video Format 1080P25
Recovery Default	
	【#】+【#】+【8】： Switching Video Format 720P30
	【#】+【#】+【9】： Switching Video Format 720P25

Note: If the address of the remote control used before is not 1, but one of 2, 3, 4;
After restoring the default of the factory, the product address corresponding to the remote controller will be restored to 1;
At this time, it is necessary to change the address of the remote controller back to 1, that is, press the remote controller to select the [1] key and then control normally.

3.3 Menu introduction

Note: To modify the parameters in the menu, you need to exit the menu before you can save it by power off.

1) Menu Control Key

- 【MENU】： Enter/exit OSD menu or return to previous menu
- 【HOME】： Go to the next menu
- 【↑】 【↓】： Select controls
- 【←】 【→】： Modify parameter values

2) English menu interface

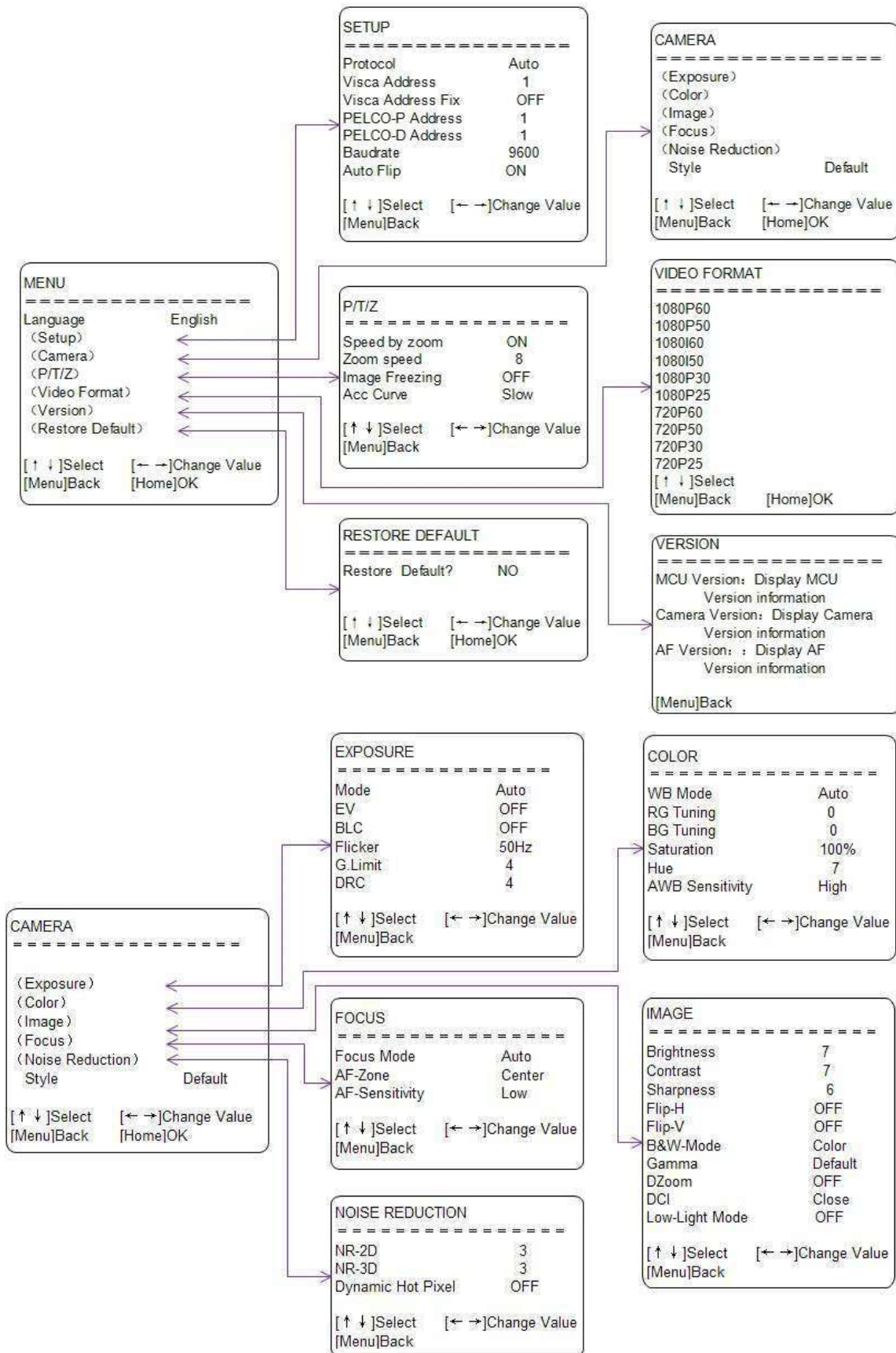

4. Network Connection

4.1. Network Connection

Direct connection: Connect the camera and computer by network connecting cable.

Internet connection mode: Connect the camera to Internet by Router or Switch and user can log in the device by browser.

Note: Please do not put the power and network cable in places where can be easily touched to prevent video quality lowered by unstable signal transmission due to poor contact of cables.

The computer must have the network segment where the camera IP address belongs to. The device will not be accessible if without the segment. I.E. The camera default IP address is 192.168.5.163, then segment 5 must be added in the computer. Specific steps are as below:

Firstly, open the window of Local Area Connection Properties on computer, select the “Internet protocol version 4(TCP/IPv4)” as shown by picture. Double click or click the property “Internet” protocol version 4 (TCP/IPv4) to enter into the Internet Protocol Version 4(TCP/IPv4) Properties window, select “Advanced” to enter into the Advanced TCP/IP Setting and add IP and subnet mask (192.168.5.26 / 255.255.255.0) in the IP browser as picture shown below. Click the “Confirm” to finish the adding of IP segment. User can add the corresponding network segment according to the revised IP address of the camera.

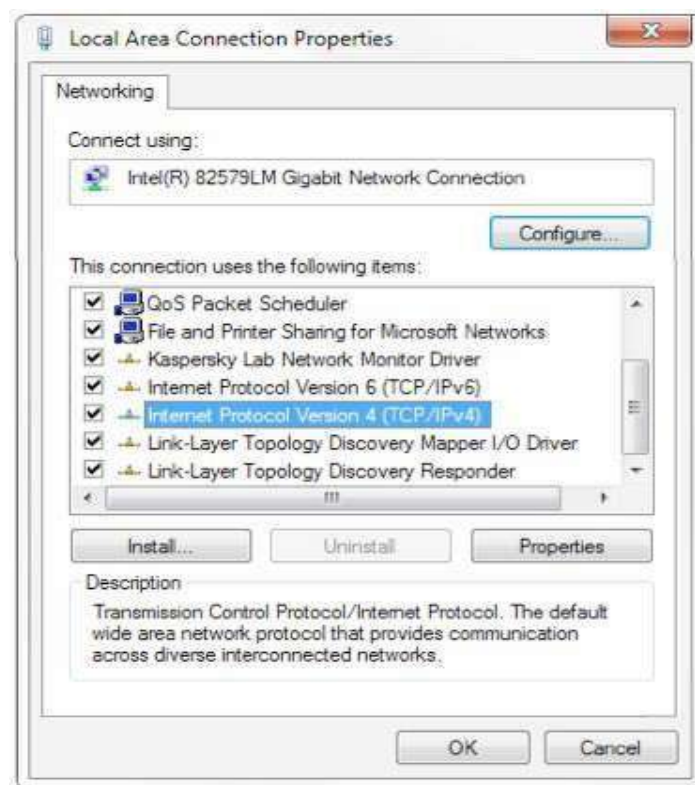

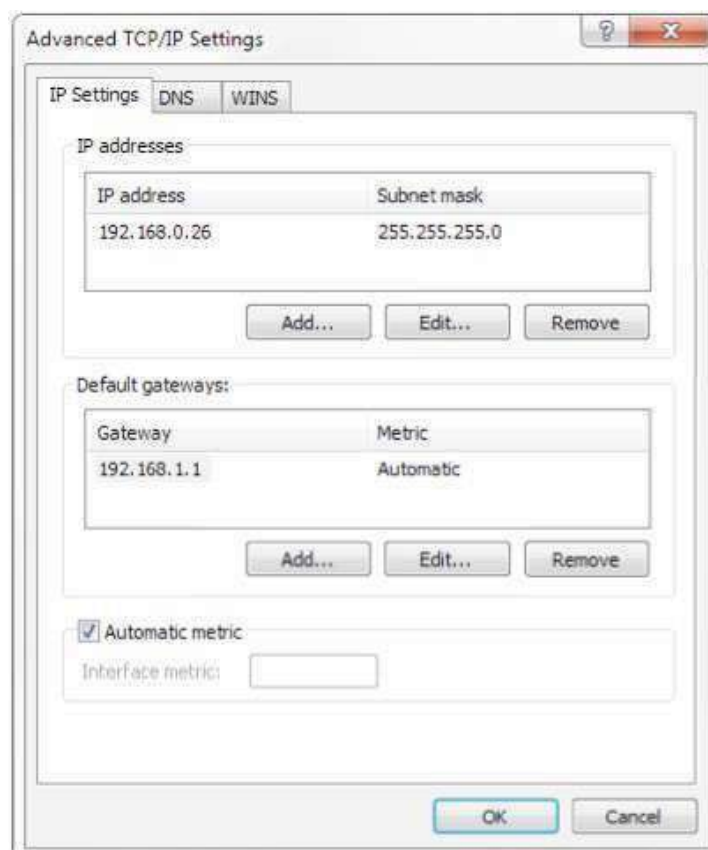
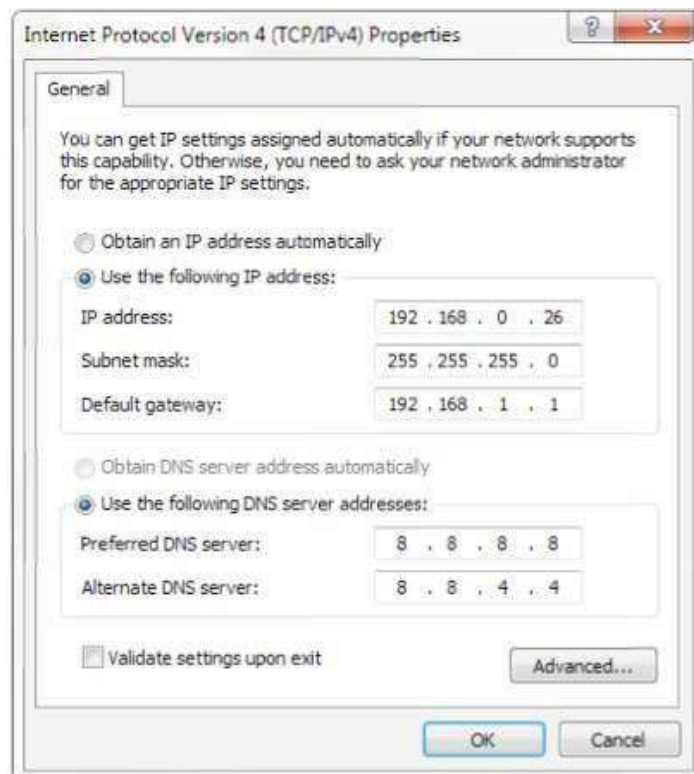

Note: The IP address to be added cannot be same with that of other computers or devices. The existence of this IP address needs to be verified before adding.

Click the “Start” and select “Operation” to input cmd as picture below to verify if the network segment has been successfully added.



User can verify network connection as steps above mentioned after the finish of camera self-check. If IP is default, open DOS command window and input 192.168.5.163, then press Enter key. It will show message as below: which means network connection is normal.

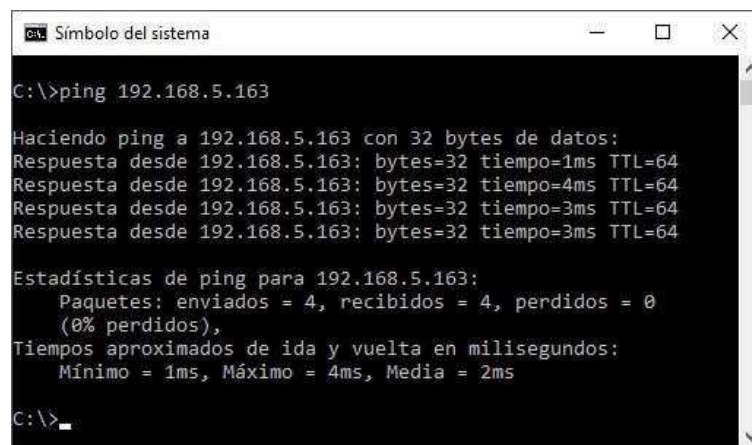

4.2 Internet Explorer Log In

1. Web client Log In

Input the IP address 192.168.5.163 of the device in the address filed of browser and click Enter button to enter into Web Client login page as below picture. User can login as administrator and normal user. If login as administrator (**Default User name/Password: admin**), users can preview, playback, configuration and cancel in the Web Client; If login in as normal user(Default User name/Password:user1 or user2),users can only preview, playback and cancel, no option for configuration.

Language Selection: The upper right corner of the login interface shows "Chinese | English" clickers can choose the language type of the web interface.

Note: Web access supported browsers: IE,360 browser and other conventional browser.

2. Web login

Enter the username and password, click login (initial default username and password is "admin". After entering, you can change the username and password by yourself), and enter the Web client management interface.

5. Serial Communication Control

Under common working condition, the camera could be controlled through RS232/RS485 interface (VISCA), RS232C serial parameter are as follows:

Baud rate: 2400/4800/9600/115200 bits / sec; Start bit: 1; data bits: 8; Stop bit: 1; Parity: None.

After power on, the camera first go left, then back to the middle position. Self-test is finished after the zoom moved to the farthest and then back to the nearest position. If the camera saved 0 preset before, it will be back to that position after initialization. At this point, the user can control the camera by the serial commands.

5.1 VISCA protocol list

5.1.1 Camera return command

Ack/Completion Message		
	Command packet	Note
ACK	z0 41 FF	Returned when the command is accepted.
Completion	z0 51 FF	Returned when the command has been executed.

z = camera address + 8

Error Messages		
	Command packet	Note
Syntax Error	z0 60 02 FF	Returned when the command format is different or when a command with illegal command parameters is accepted
Command Not Executable	z0 61 41 FF	Returned when a command cannot be executed due to current conditions. For example, when commands controlling the focus manually are received during auto focus.

5.1.2 Camera control command

Command	Function	Command packet	Note
AddressSet	Broadcast	88 30 0p FF	p: Address setting
IF_Clear	Broadcast	88 01 00 01 FF	I/F Clear
CommandCancel		8x 21 FF	
CAM_Power	On	8x 01 04 00 02 FF	Power ON/OFF
	Off	8x 01 04 00 03 FF	
CAM_Zoom	Stop	8x 01 04 07 00 FF	p = 0(low) - F(high) pqrs: Zoom Position
	Tele(Standard)	8x 01 04 07 02 FF	
	Wide(Standard)	8x 01 04 07 03 FF	
	Tele(Variable)	8x 01 04 07 2p FF	
	Wide(Variable)	8x 01 04 07 3p FF	
	Direct	8x 01 04 47 0p 0q 0r 0s FF	
	Stop	8x 01 04 08 00 FF	

Command	Function	Command packet	Note
CAM_Focus	Far(Standard)	8x 01 04 08 02 FF	p = 0(low) - F(high)
	Near(Standard)	8x 01 04 08 03 FF	
	Far(Variable)	8x 01 04 08 2p FF	
	Near (Variable)	8x 01 04 08 3p FF	
	Direct	8x 01 04 48 0p 0q 0r 0s FF	pqrs: Focus Position
	Auto Focus	8x 01 04 38 02 FF	
	One Push Mode	8x 01 04 38 04 FF	
	Manual Focus	8x 01 04 38 03 FF	
CAM_Zoom Focus	Direct	8x 01 04 47 0p 0q 0r 0s 0t 0u 0v 0w FF	pqrs: Zoom Position tuvw: Focus Position
CAM_WB	Auto	8x 01 04 35 00 FF	
	3000K	8x 01 04 35 01 FF	
	4000k	8x 01 04 35 02 FF	
	One Push mode	8x 01 04 35 03 FF	
	5000k	8x 01 04 35 04 FF	
	Manual	8x 01 04 35 05 FF	
	6500k	8x 01 04 35 06 FF	
	3500K	8x 01 04 35 07 FF	
	4500K	8x 01 04 35 08 FF	
	5500K	8x 01 04 35 09 FF	
	6000K	8x 01 04 35 0A FF	
	7000K	8x 01 04 35 0B FF	
CAM_RGain	Reset	8x 01 04 03 00 FF	Manual Control of R Gain
	Up	8x 01 04 03 02 FF	
	Down	8x 01 04 03 03 FF	
	Direct	8x 01 04 43 00 00 0p 0q FF	pq: R Gain
CAM_Bgain	Reset	8x 01 04 04 00 FF	Manual Control of B Gain
	Up	8x 01 04 04 02 FF	
	Down	8x 01 04 04 03 FF	
	Direct	8x 01 04 44 00 00 0p 0q FF	pq: B Gain
CAM_AE	Full Auto	8x 01 04 39 00 FF	Automatic Exposure mode
	Manual	8x 01 04 39 03 FF	Manual Control mode
	Shutter priority	8x 01 04 39 0A FF	Shutter Priority Automatic Exposure mode
	Iris priority	8x 01 04 39 0B FF	Iris Priority Automatic Exposure mode
	Bright	8x 01 04 39 0D FF	Bright mode
CAM_Shutter	Reset	8x 01 04 0A 00 FF	Shutter Setting
	Up	8x 01 04 0A 02 FF	
	Down	8x 01 04 0A 03 FF	
	Direct	8x 01 04 4A 00 00 0p 0q FF	pq: Shutter Position
CAM_Iris	Reset	8x 01 04 0B 00 FF	Iris Setting
	Up	8x 01 04 0B 02 FF	
	Down	8x 01 04 0B 03 FF	
	Direct	8x 01 04 4B 00 00 0p 0q FF	pq: Iris Position
CAM_Gain Limit	Gain Limit	8x 01 04 2C 0p FF	p: Gain Positon
CAM_Bright	Reset	8x 01 04 0D 00 FF	Bright Setting
	Up	8x 01 04 0D 02 FF	

Command	Function	Command packet	Note
	Down	8x 01 04 0D 03 FF	
	Direct	8x 01 04 4D 00 00 0p 0q FF	pq: Bright Positon
CAM_ExpComp	On	8x 01 04 3E 02 FF	Exposure Compensation ON/OFF
	Off	8x 01 04 3E 03 FF	
	Reset	8x 01 04 0E 00 FF	Exposure Compensation Amount Setting
	Up	8x 01 04 0E 02 FF	
	Down	8x 01 04 0E 03 FF	
	Direct	8x 01 04 4E 00 00 0p 0q FF	pq: ExpComp Position
CAM_Back Light	On	8x 01 04 33 02 FF	Back Light Compensation
	Off	8x 01 04 33 03 FF	
CAM_WDRStrength	Reset	8x 01 04 21 00 FF	WDR Level Setting
	Up	8x 01 04 21 02 FF	
	Down	8x 01 04 21 03 FF	
	Direct	8x 01 04 51 00 00 00 0p FF	p: WDR Level Positon
CAM_NR (2D)		8x 01 04 53 0p FF	P=0-7 0:OFF
CAM_NR (3D)		8x 01 04 54 0p FF	P=0-8 0:OFF
CAM_Gamma		8x 01 04 5B 0p FF	p = 0 – 4 0: Default 1: 0.47 2: 0.50 3: 0.52 4: 0.55
CAM_Flicker	OFF	8x 01 04 23 00 FF	OFF
	50HZ	8x 01 04 23 01 FF	50HZ
	60HZ	8x 01 04 23 02 FF	60HZ
CAM_Aperture	Reset	8x 01 04 02 00 FF	Aperture Control
	Up	8x 01 04 02 02 FF	
	Down	8x 01 04 02 03 FF	
	Direct	8x 01 04 42 00 00 0p 0q FF	pq: Aperture Gain
CAM_Memory	Reset	8x 01 04 3F 00 pq FF	pq: Memory Number(=0 to 254) Corresponds to 0 to 9 on the Remote Commander
	Set	8x 01 04 3F 01 pq FF	
	Recall	8x 01 04 3F 02 pq FF	
CAM_LR_Reverse	On	8x 01 04 61 02 FF	Image Flip Horizontal ON/OFF
	Off	8x 01 04 61 03 FF	
CAM_PictureFlip	On	8x 01 04 66 02 FF	Image Flip Vertical ON/OFF
	Off	8x 01 04 66 03 FF	
CAM_ColorSaturation	Direct	8x 01 04 49 00 00 00 0p FF	P=0-7 0:60% 1:70% 2:80% 3:90% 4:100% 5:110% 6:120% 7:130%
CAM_IDWrite		8x 01 04 22 0p 0q 0r 0s FF	pqrs: Camera ID (=0000 to FFFF)
SYS_Menu	ON	8x 01 04 06 06 02 FF	Turn on the menu screen
	OFF	8x 01 04 06 06 03 FF	Turn off the menu screen
IR_Receive	ON	8x 01 06 08 02 FF	IR(remote commander)receive On/Off
	OFF	8x 01 06 08 03 FF	
IR_ReceiveReturn	On	8x 01 7D 01 03 00 00 FF	IR(remote commander)receive message via the VISCA communication ON/OFF
	Off	8x 01 7D 01 13 00 00 FF	
CAM_SettingReset	Reset	8x 01 04 A0 10 FF	Reset Factory Setting
CAM_Brightness	Direct	8x 01 04 A1 00 00 0p 0q FF	pq: Brightness Position
CAM_Contrast	Direct	8x 01 04 A2 00 00 0p 0q FF	pq: Contrast Position
CAM_Flip	OFF	8x 01 04 A4 00 FF	Single Command For Video Flip
	Flip-H	8x 01 04 A4 01 FF	

Command	Function	Command packet	Note
	Flip-V	8x 01 04 A4 02 FF	
	Flip-HV	8x 01 04 A4 03 FF	
CAM_VideoSystem	Set camera video system	8x 01 06 35 00 0p FF	P: 0~E Video format 0:1080P60 8:720P30 1:1080P50 9:720P25 2:1080i60 A: 1080P59.94 3:1080i50 B: 1080i59.94 4:720P60 C: 720P59.94 5:720P50 D: 1080P29.97 6:1080P30 E: 720P29.97 7:1080P25
Pan_tiltDrive	Up	8x 01 06 01 VV WW 03 01 FF	VV: Pan speed 0x01 (low speed) to 0x18 (high speed) WW: Tilt speed 0x01 (low speed) to 0x14 (high speed) YYYY: Pan Position ZZZZ: Tilt Position
	Down	8x 01 06 01 VV WW 03 02 FF	
	Left	8x 01 06 01 VV WW 01 03 FF	
	Right	8x 01 06 01 VV WW 02 03 FF	
	Upleft	8x 01 06 01 VV WW 01 01 FF	
	Upright	8x 01 06 01 VV WW 02 01 FF	
	DownLeft	8x 01 06 01 VV WW 01 02 FF	
	DownRight	8x 01 06 01 VV WW 02 02 FF	
	Stop	8x 01 06 01 VV WW 03 03 FF	
	AbsolutePosition	8x 01 06 02 VV WW 0Y 0Y 0Y 0Y 0Z 0Z 0Z 0Z FF	
	RelativePosition	8x 01 06 03 VV WW 0Y 0Y 0Y 0Y 0Z 0Z 0Z 0Z FF	
	Home	8x 01 06 04 FF	
	Reset	8x 01 06 05 FF	
Pan-tiltLimitSet	Set	8x 01 06 07 00 0W 0Y 0Y 0Y 0Y 0Z 0Z 0Z 0Z FF	W:1 UpRight 0:DownLeft YYYY: Pan Limit Position(TBD) ZZZZ: Tilt Limit Position(TBD)
	Clear	8x 01 06 07 01 0W 07 0F 0F 0F 07 0F 0F 0F FF	

5.1.3 Inquiry command

Command	Function	Command packet	Note
CAM_PowerInq	8x 09 04 00 FF	y0 50 02 FF	On
		y0 50 03 FF	Off(Standby)
CAM_ZoomPosInq	8x 09 04 47 FF	y0 50 0p 0q 0r 0s FF	pqrs: Zoom Position
CAM_FocusAFModelInq	8x 09 04 38 FF	y0 50 02 FF	Auto Focus
		y0 50 03 FF	Manual Focus
		y0 50 04 FF	One Push mode
CAM_FocusPosInq	8x 09 04 48 FF	y0 50 0p 0q 0r 0s FF	pqrs: Focus Position
CAM_WBModelInq	8x 09 04 35 FF	y0 50 00 FF	Auto
		y0 50 01 FF	3000K
		y0 50 02 FF	4000K
		y0 50 03 FF	One Push Mode
		y0 50 04 FF	5000K
		y0 50 05 FF	Manual
		y0 50 00 FF	6500K
		y0 50 06 FF	6500K
		y0 50 07 FF	3500K
		y0 50 08 FF	4500K
		y0 50 09 FF	5500K
		y0 50 0A FF	6000K
		y0 50 0B FF	7000K

CAM_RGainInq	8x 09 04 43 FF	y0 50 00 00 0p 0q FF	pp: R Gain
CAM_BGainInq	8x 09 04 44 FF	y0 50 00 00 0p 0q FF	pp: B Gain
CAM_AEModeInq	8x 09 04 39 FF	y0 50 00 FF	Full Auto
		y0 50 03 FF	Manual
		y0 50 0A FF	Shutter priority
		y0 50 0B FF	Iris priority
		y0 50 0D FF	Bright
CAM_ShutterPosInq	8x 09 04 4A FF	y0 50 00 00 0p 0q FF	pp: Shutter Position
CAM_IrisPosInq	8x 09 04 4B FF	y0 50 00 00 0p 0q FF	pp: Iris Position
CAM_Gain LimitInq	8x 09 04 2C FF	y0 50 0p FF	p: Gain Positon
CAM_BrightPosInq	8x 09 04 4D FF	y0 50 00 00 0p 0q FF	pp: Bright Position
CAM_ExpCompModelInq	8x 09 04 3E FF	y0 50 02 FF	On
		y0 50 03 FF	Off
CAM_ExpCompPosInq	8x 09 04 4E FF	y0 50 00 00 0p 0q FF	pp: ExpComp Position
CAM_BacklightModelInq	8x 09 04 33 FF	y0 50 02 FF	On
		y0 50 03 FF	Off
CAM_WDRStrengthInq	8x 09 04 51 FF	y0 50 00 00 00 0p FF	p: WDR Strength
CAM_NRLevel(2D) Inq	8x 09 04 53 FF	y0 50 0p FF	P: 2DNRLLevel
CAM_NRLevel(3D) Inq	8x 09 04 54 FF	y0 50 0p FF	P:3D NRLevel
CAM_FlickerModelInq	8x 09 04 55 FF	y0 50 0p FF	p: Flicker Settings(0: OFF,1: 50Hz,2:60Hz)
CAM_ApertureInq	8x 09 04 42 FF	y0 50 00 00 0p 0q FF	pp: Aperture Gain
CAM_PictureEffectModelInq	8x 09 04 63 FF	y0 50 00 FF	Off
		y0 50 04 FF	B&W
CAM_MemoryInq	8x 09 04 3F FF	y0 50 0p FF	p: Memory number last operated.
SYS_MenuModelInq	8x 09 06 06 FF	y0 50 02 FF	On
		y0 50 03 FF	Off
CAM_LR_ReverseInq	8x 09 04 61 FF	y0 50 02 FF	On
		y0 50 03 FF	Off
CAM_PictureFlipInq	8x 09 04 66 FF	y0 50 02 FF	On
		y0 50 03 FF	Off
CAM_ColorSaturationInq	8x 09 04 49 FF	y0 50 00 00 00 0p FF	p: Color Gain setting 0h (60%) to Eh (130%)
CAM_IDInq	8x 09 04 22 FF	y0 50 0p FF	p: Gamma ID
IR_ReceiveInq	8x 09 06 08 FF	y0 50 02 FF	On
		y0 50 03 FF	Off
IR_ReceiveReturn		y0 07 7D 01 04 00 FF	Power ON/OFF
		y0 07 7D 01 04 07 FF	Zoom tele/wide
		y0 07 7D 01 04 38 FF	AF ON/OFF
		y0 07 7D 01 04 33 FF	Camera_Backlight
		y0 07 7D 01 04 3F FF	Camera_Memery
		y0 07 7D 01 06 01 FF	Pan_titleDriver
CAM_BrightnessInq	8x 09 04 A1 FF	y0 50 00 00 0p 0q FF	pp: Brightness Position
CAM_ContrastInq	8x 09 04 A2 FF	y0 50 00 00 0p 0q FF	pp: Contrast Position
CAM_FlipInq	8x 09 04 A4 FF	y0 50 00 FF	Off
		y0 50 01 FF	Flip-H
		y0 50 02 FF	Flip-V
		y0 50 03 FF	Flip-HV
CAM_GammaInq	8x 09 04 5B FF	y0 50 0p FF	p: Gamma setting
CAM_VersionInq	8x 09 00 02 FF	y0 50 ab cd mn pq rs tu vw FF	ab cd : vender ID (0220) mn pq : model ID ST (0950) U3 (3950) rs tu : ARM Version vw : reserve
VideoSystemInq	8x 09 06 23 FF	y0 50 0p FF	P: 0~E Video format 0:1080P60 8:720P30 1:1080P50 9:720P25 2:1080i60 A: 1080P59.94 3:1080i50

			B: 1080i59.94 4:720P60 C: 720P59.94 5:720P50 D: 1080P29.97 6:1080P30 7:1080P25 E:
Pan-tiltMaxSpeedInq	8x 09 06 11 FF	y0 50 ww zz FF	ww: Pan Max Speed zz: Tilt Max Speed
Pan-tiltPosInq	8x 09 06 12 FF	y0 50 0w 0w 0w 0w Oz Oz Oz Oz FF	www: Pan Position zzzz: Tilt Position

Note:[X] in the above table indicates the camera address to be operated, **【y】 = 【x + 8】** .

5.2 Pelco-D protocol command list

Function	Byte1	Byte2	Byte3	Byte4	Byte5	Byte6	Byte7
Up	0xFF	Address	0x00	0x08	Pan Speed	Tilt Speed	SUM
Down	0xFF	Address	0x00	0x10	Pan Speed	Tilt Speed	SUM
Left	0xFF	Address	0x00	0x04	Pan Speed	Tilt Speed	SUM
Right	0xFF	Address	0x00	0x02	Pan Speed	Tilt Speed	SUM
Upleft	0xFF	Address	0x00	0x0C	Pan Speed	Tilt Speed	SUM
Upright	0xFF	Address	0x00	0x0A	Pan Speed	Tilt Speed	SUM
DownLeft	0xFF	Address	0x00	0x14	Pan Speed	Tilt Speed	SUM
DownRight	0xFF	Address	0x00	0x12	Pan Speed	Tilt Speed	SUM
Zoom In	0xFF	Address	0x00	0x20	0x00	0x00	SUM
Zoom Out	0xFF	Address	0x00	0x40	0x00	0x00	SUM
Focus Far	0xFF	Address	0x00	0x80	0x00	0x00	SUM
Focus Near	0xFF	Address	0x01	0x00	0x00	0x00	SUM
Set Preset	0xFF	Address	0x00	0x03	0x00	Preset ID	SUM
Clear Preset	0xFF	Address	0x00	0x05	0x00	Preset ID	SUM
Call Preset	0xFF	Address	0x00	0x07	0x00	Preset ID	SUM
Query Pan Position	0xFF	Address	0x00	0x51	0x00	0x00	SUM
Query Pan Position Response	0xFF	Address	0x00	0x59	Value High Byte	Value Low Byte	SUM
Query Tilt Position	0xFF	Address	0x00	0x53	0x00	0x00	SUM
Query Tilt Position Response	0xFF	Address	0x00	0x5B	Value High Byte	Value Low Byte	SUM
Query Zoom Position	0xFF	Address	0x00	0x55	0x00	0x00	SUM
Query Zoom Position Response	0xFF	Address	0x00	0x5D	Value High Byte	Value Low Byte	SUM

5.3 Pelco-P protocol command list

Function	Byte1	Byte2	Byte3	Byte4	Byte5	Byte6	Byte7	Byte8
Up	0xA0	Address	0x00	0x08	Pan Speed	Tilt Speed	0xAF	XOR
Down	0xA0	Address	0x00	0x10	Pan Speed	Tilt Speed	0xAF	XOR
Left	0xA0	Address	0x00	0x04	Pan Speed	Tilt Speed	0xAF	XOR
Right	0xA0	Address	0x00	0x02	Pan Speed	Tilt Speed	0xAF	XOR
Upleft	0xA0	Address	0x00	0x0C	Pan Speed	Tilt Speed	0xAF	XOR
Upright	0xA0	Address	0x00	0x0A	Pan Speed	Tilt Speed	0xAF	XOR
DownLeft	0xA0	Address	0x00	0x14	Pan Speed	Tilt Speed	0xAF	XOR
DownRight	0xA0	Address	0x00	0x12	Pan Speed	Tilt Speed	0xAF	XOR
Zoom In	0xA0	Address	0x00	0x20	0x00	0x00	0xAF	XOR
Zoom Out	0xA0	Address	0x00	0x40	0x00	0x00	0xAF	XOR
Focus Far	0xA0	Address	0x01	0x00	0x00	0x00	0xAF	XOR
Focus Near	0xA0	Address	0x02	0x00	0x00	0x00	0xAF	XOR
Set Preset	0xA0	Address	0x00	0x03	0x00	Preset ID	0xAF	XOR
Clear Preset	0xA0	Address	0x00	0x05	0x00	Preset ID	0xAF	XOR
Call Preset	0xA0	Address	0x00	0x07	0x00	Preset ID	0xAF	XOR
Query Pan Position	0xA0	Address	0x00	0x51	0x00	0x00	0xAF	XOR
Query Pan Position Response	0xA0	Address	0x00	0x59	Value High Byte	Value Low Byte	0xAF	XOR
Query Tilt Position	0xA0	Address	0x00	0x53	0x00	0x00	0xAF	XOR
Query Tilt Position Response	0xA0	Address	0x00	0x5B	Value High Byte	Value Low Byte	0xAF	XOR
Query Zoom Position	0xA0	Address	0x00	0x55	0x00	0x00	0xAF	XOR
Query Zoom Position Response	0xA0	Address	0x00	0x5D	Value High Byte	Value Low Byte	0xAF	XOR

6. Maintenance and troubleshooting

6.1. Product maintenance

1) If the equipment is not in long-term use, disconnect the power switch when not in use and disconnect the AC power adapter from the AC socket.

2) When removing dust from the outer shell of the equipment, please use soft cloth or cotton paper to avoid scratches.

When cleaning equipment lens, please use dry soft cloth to wipe, if dirt is serious, please use neutral detergent to wipe gently. Do not use strong or corrosive detergents to avoid lens scratches and affect image effects.

6.2 Troubleshooting

1) Video output without image

Solution:

- A. Check whether the power supply of the equipment is properly connected and whether the power indicator is on
- B. Whether the power-off restart equipment is normal or not
- C. Check whether the bottom dial switch is working in normal mode (see Table 2.2 and Table 2.3)
- D. Check whether the connection of video output and video display is normal

2) Images are sometimes absent

Solution: A. Check whether the connection of video output and video display is normal³⁾

Lens zoom image jitter

Solution:

- A. Check whether the installation position of the equipment is firm or not
- B. Are there any vibrating machinery or objects around the equipment?

4) Remote Controller Not Controllable

Solution:

- A. Is the remote control address set to 1 controllable (if the equipment restores the factory default value, the remote control address is also restored to 1)
- B. Check whether the remote control battery is installed or the power supply is insufficient
- C. Check whether the working mode of the equipment is normal (see Table 2.2 and Table 2.3)
- D. Check whether the menu has not exited, then it can be controlled normally after exiting the menu. If the page outputs images, it will not display the menu and do nothing. After 30 seconds, the menu automatically exits and can be controlled.

5) Serial Port Can't Be Controlled

Solution:

- A. Whether to allocate control lines for our company?
- B. Check whether the protocol, baud rate and address of serial devices are consistent with the equipment.

- C. Check whether the control line is connected properly
- D. Check whether the working mode of the equipment is normal (see Table 2.2 and Table 2.3)

6) Web pages cannot be logged in

Solution:

- a. Check whether the equipment is working properly with the display.
- B. Check whether the network connection is normal (the yellow indicator flashes at the outlet, indicating that the network connection is normal)
- C. Check whether the computer adds a network segment and the network segment is identical to the device IP address
- D. Open "Start" in the computer, select "Run" and enter cmd; click "OK" and then open the computer DOS command window and enter Ping 192.168.5.163. Press the Enter key and the information appears as follows: Describe the network connection.

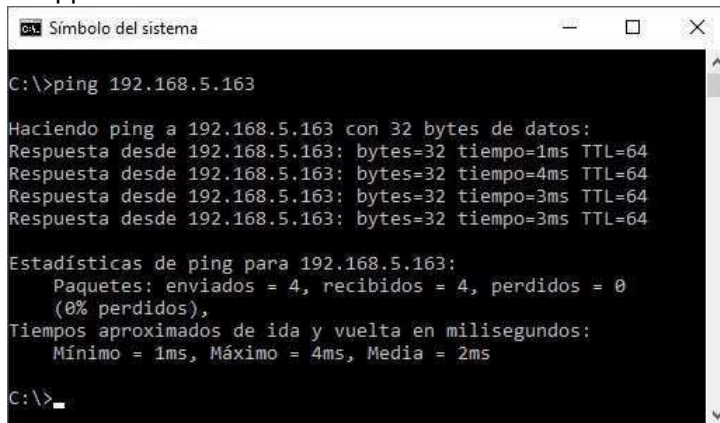

```
Símbolo del sistema
C:\>ping 192.168.5.163

Haciendo ping a 192.168.5.163 con 32 bytes de datos:
Respuesta desde 192.168.5.163: bytes=32 tiempo=1ms TTL=64
Respuesta desde 192.168.5.163: bytes=32 tiempo=4ms TTL=64
Respuesta desde 192.168.5.163: bytes=32 tiempo=3ms TTL=64
Respuesta desde 192.168.5.163: bytes=32 tiempo=3ms TTL=64

Estadísticas de ping para 192.168.5.163:
    Paquetes: enviados = 4, recibidos = 4, perdidos = 0
              (0% perdidos),
    Tiempos aproximados de ida y vuelta en milisegundos:
        Mínimo = 1ms, Máximo = 4ms, Media = 2ms

C:\>
```

Copyright

The copyright of this manual belongs to the company. Without the company's permission, it may not be copied, copied, copied or translated arbitrarily. This manual does not contain any form of guarantee, expression of position or other implications. The product specifications and information mentioned in this manual are for reference only and will be updated at any time without further notice.

Copyright is reserved and may not be reproduced.