

# Cute 10X

## User Manual

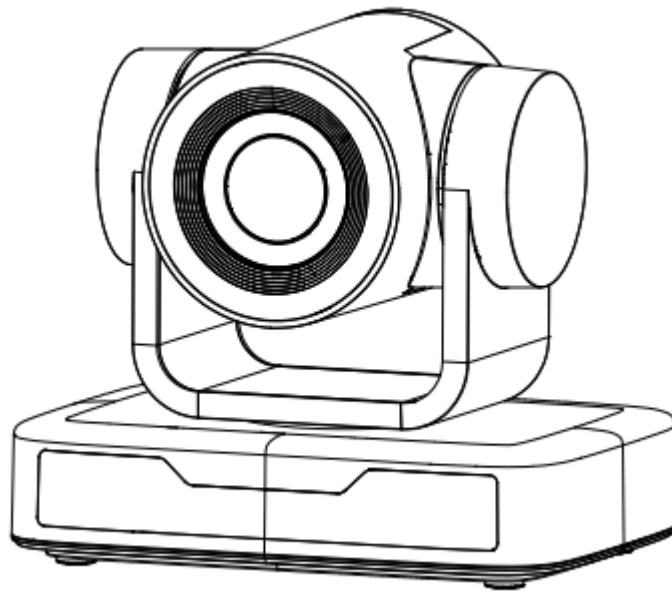



## Attentions

**This manual introduces functions, installations and operations for this PTZ camera in details. Please read this manual carefully before installation and use.**

### 1. Cautions

- 1.1 Avoid damage to product caused by heavy pressure, strong vibration or immersion during transportation, storage and installation.
- 1.2 Housing of this product is made of organic materials. Do not expose it to any liquid, gas or solids which may corrode the shell.
- 1.3 Do not expose the product to rain or moisture.
- 1.4 To prevent the risk of electric shock, do not open the case. Installation and maintenance should only be carried out by qualified technicians.
- 1.5 Do not use the product beyond the specified temperature, humidity or power supply specifications.
- 1.6 Wipe it with a soft, dry cloth when cleaning the camera lens. Wipe it gently with a mild detergent if needed. Do not use strong or corrosive detergents to avoid scratching the lens and affecting the image;
- 1.7 This product contains no parts which can be maintained by users themselves. Any damage caused by dismantling the product by user without permission is not covered by warranty.

### 2. Electrical Safety

Installation and use of this product must strictly comply with local electrical safety standards. The power supply of the product is  $\pm 12V$ , the max electrical current is 2A.



### 3. Install

- 1.1 Do not rotate the camera head violently, otherwise it may cause mechanical failure.
- 1.2 This product should be placed on a stable desktop or other horizontal surface. Do not install the product obliquely, otherwise it may display inclined image;
- 1.3 Ensure there are no obstacles within rotation range of the holder.
- 1.4 Do not power on before completely installation.

### 4. Magnetic Interference

Electromagnetic fields at specific frequencies may affect the video image. This product is Class A. It may cause radio interference in household application. Appropriate measure is required.

# Content

---

1. CAMERA INSTALLATION .....	3
1.1. CAMERA INTRODUCTION .....	3
1.2 POWER-ON INITIAL CONFIGURATION .....	3
1.3 VIDEO OUTPUT .....	4
1.4 MOUNTING BRACKETS .....	4
2. PRODUCT OVERVIEW .....	7
2.1 PRODUCT INTRODUCTION .....	7
2.1.1 Model .....	7
2.1.2 Dimension .....	7
2.1.3 Accessory .....	8
2.2 MAIN FEATURES .....	8
2.3 TECHNICAL PARAMETER .....	9
2.4 INTERFACE INSTRUCTION .....	10
2.4.1 External Interface .....	10
2.4.2 RS-232 Interface .....	11
3. APPLICATION INSTRUCTION .....	12
3.1 VIDEO OUTPUT .....	12
3.1.1 Power-On Initial Configuration .....	12
3.1.2 Video Output .....	12
3.2 REMOTE CONTROL .....	12
<b>3.2.1 Keys Introduction</b> .....	12
3.3 MENU INTRODUCTION .....	15
3.3.1 Main Menu .....	15
3.3.2 System Setting .....	16
3.3.3 Camera Setting .....	16
3.3.4 P/T/Z .....	19
3.3.5 Version .....	20
4. SERIAL PORT COMMUNICATION AND CONTROL .....	21
4.1 VISCA PROTOCOL LIST .....	21
4.1.1 VISCA Protocol Return Command .....	21
4.1.2 VISCA Protocol Control Command .....	22
4.1.3 VISCA Protocol Inquiry Command .....	24
4.2 PELCO-D PROTOCOL COMMAND LIST .....	26
4.3 PELCO-P PROTOCOL COMMAND LIST .....	27
5. MAINTENANCE AND TROUBLESHOOTING .....	28
5.1 CAMERA MAINTENANCE .....	28
5.2 TROUBLESHOOTING .....	28

# 1. Camera Installation

## 1.1. Camera Introduction

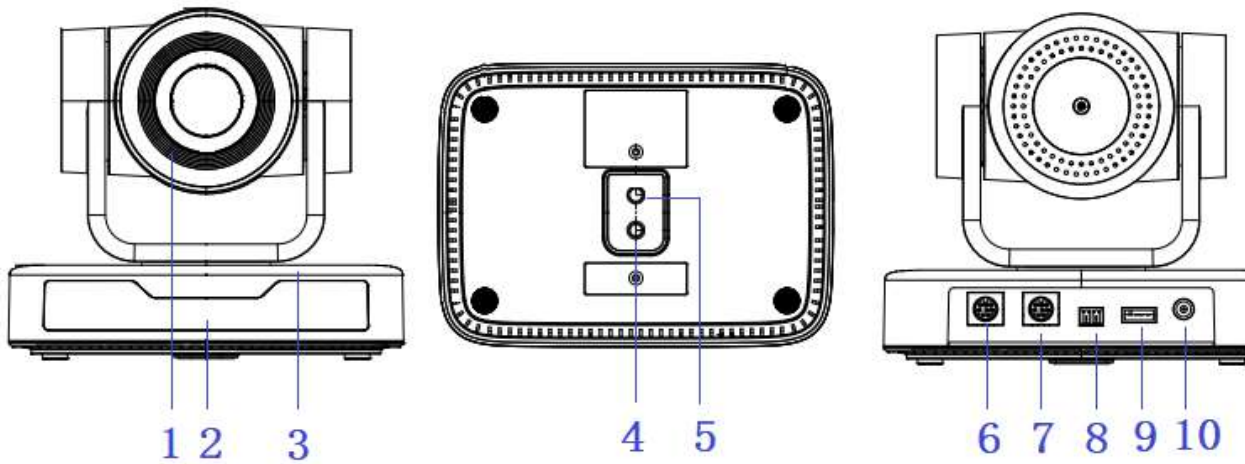

Figure 1.1 Product Interfaces

- |                                       |                                     |                                     |
|---------------------------------------|-------------------------------------|-------------------------------------|
| 1. Camera Lens                        | 5. Screw Hole for Tripod            | 9. USB 2.0 Interface                |
| 2. Remote Control Receiving Indicator | 6. RS232 Control Interface (Input)  | 10. DC12V Input Power Supply Socket |
| 3. Camera Base                        | 7. RS232 Control Interface (Output) |                                     |
| 4. Tripod Screw Hole                  | 8. RS485 Input (left +, right-)     |                                     |

## 1.2 Power-on Initial Configuration

- 1) Power-on: Connect DC12V power supply adapter with power supply socket
- 2) Initial Configuration: The remote control receiving indicator flashes after power on, the pan-tilt turns left to the lowest left to the lowest, and then turns to the HOME position (both the horizontal and vertical positions are in the middle), while the movement first shrinks and then stretches. When remote control receiving indicator stops flashing, the self-checking is completed.

### Notes:

- 1) After power on and self-checking, the camera will automatically return to the preset 0 position if it's pre-set.
- 2) The default address for the IR remote control is 1#. If the menu restored to factory defaults, the remote control default address will restore to 1#.

## 1.3 Video Output

### USB2.0 Video Output

- USB 2.0 video cable connection: as shown in Figure1.1 interface 9
- Connect the camera and the computer via USB2.0 video cable, open the video software and select the image device to output the video.

## 1.4 Mounting Brackets

Notes: Ceiling or wall mounting brackets can only be mounted on template and concrete wall.

For safety reason, plasterboard is not recommended.

### 1) Wall Mounting:

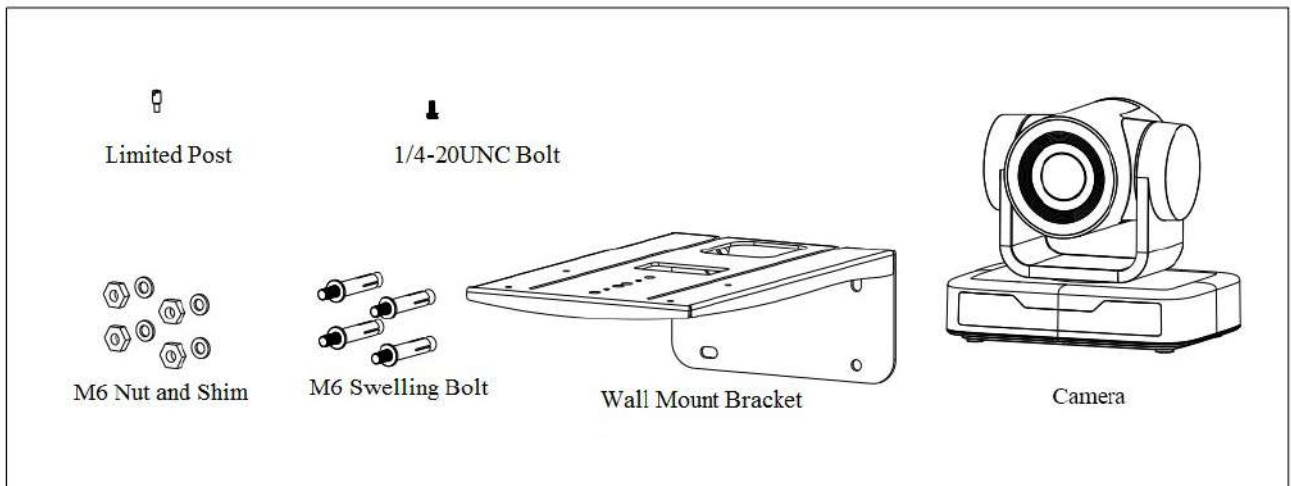

STEP 1

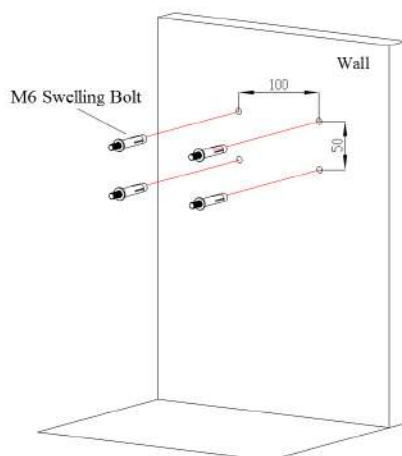

STEP 2

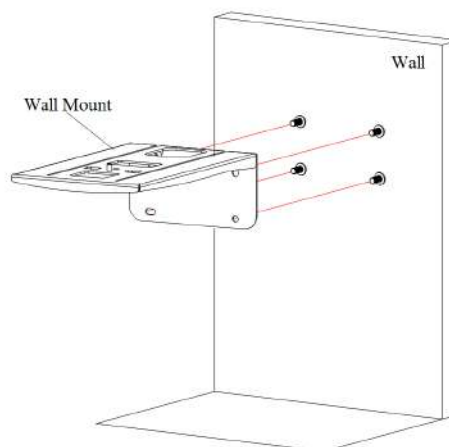

STEP 3

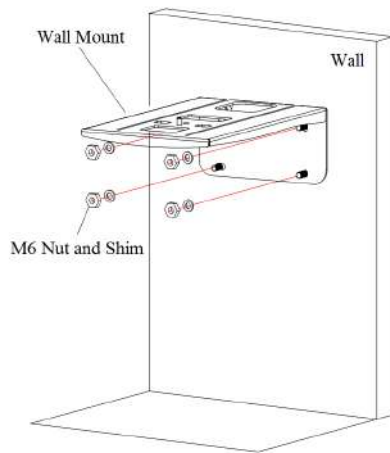

STEP 4

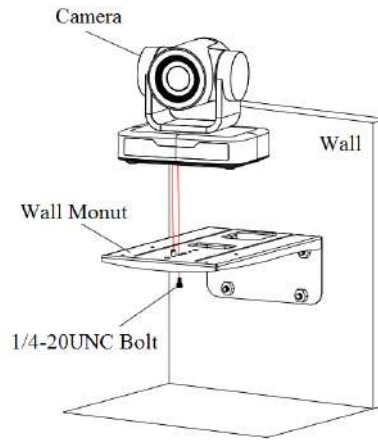

FINISH

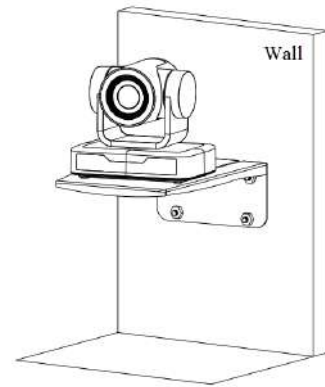

## 2) Ceiling Mounting

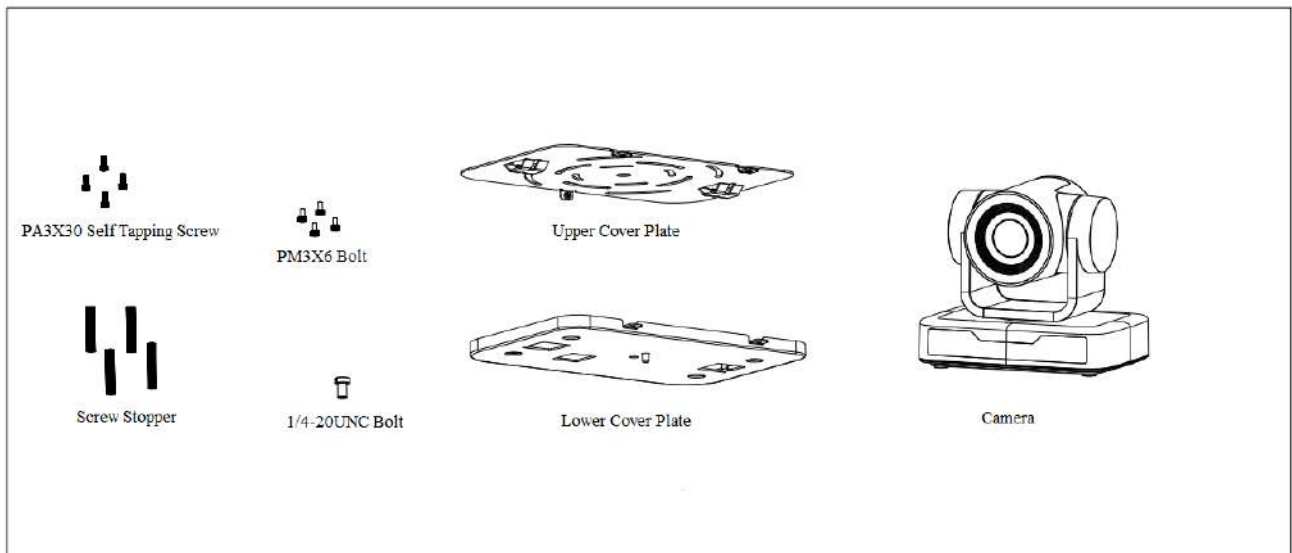

STEP 1

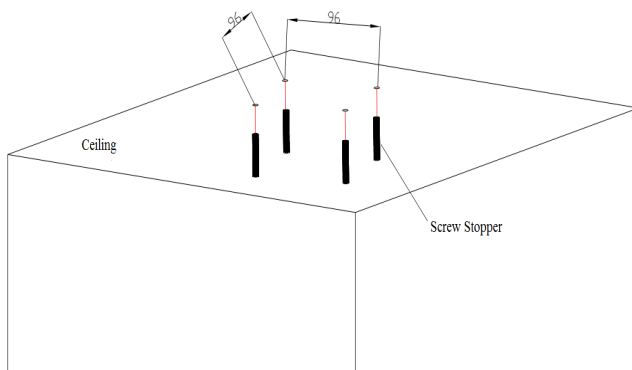

STEP 2

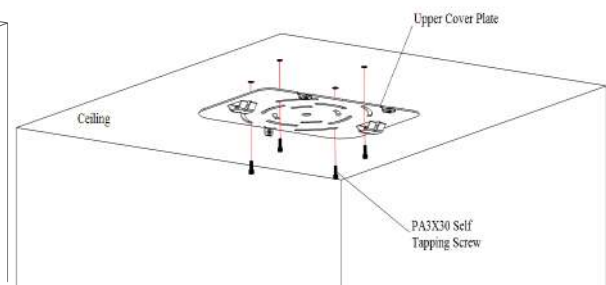

STEP 3

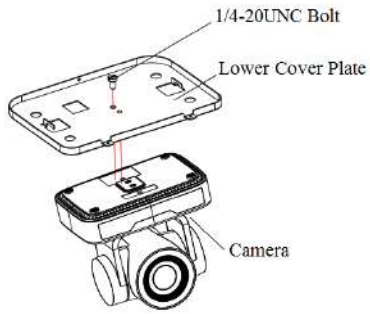

STEP 4

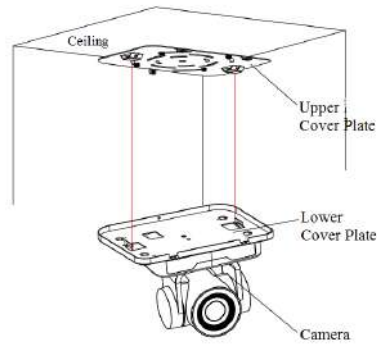

FINISH

STEP 5

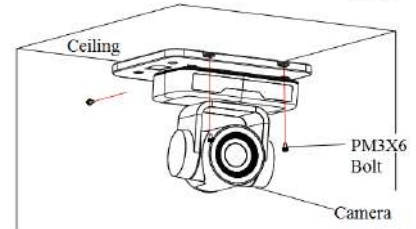

## 2. Product Overview

### 2.1 Product Introduction

#### 2.1.1 Model

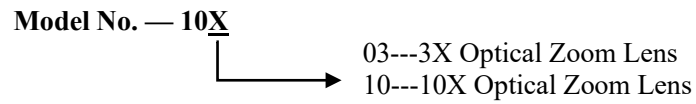

Figure 2.1 Product Model

#### 2.1.2 Dimension

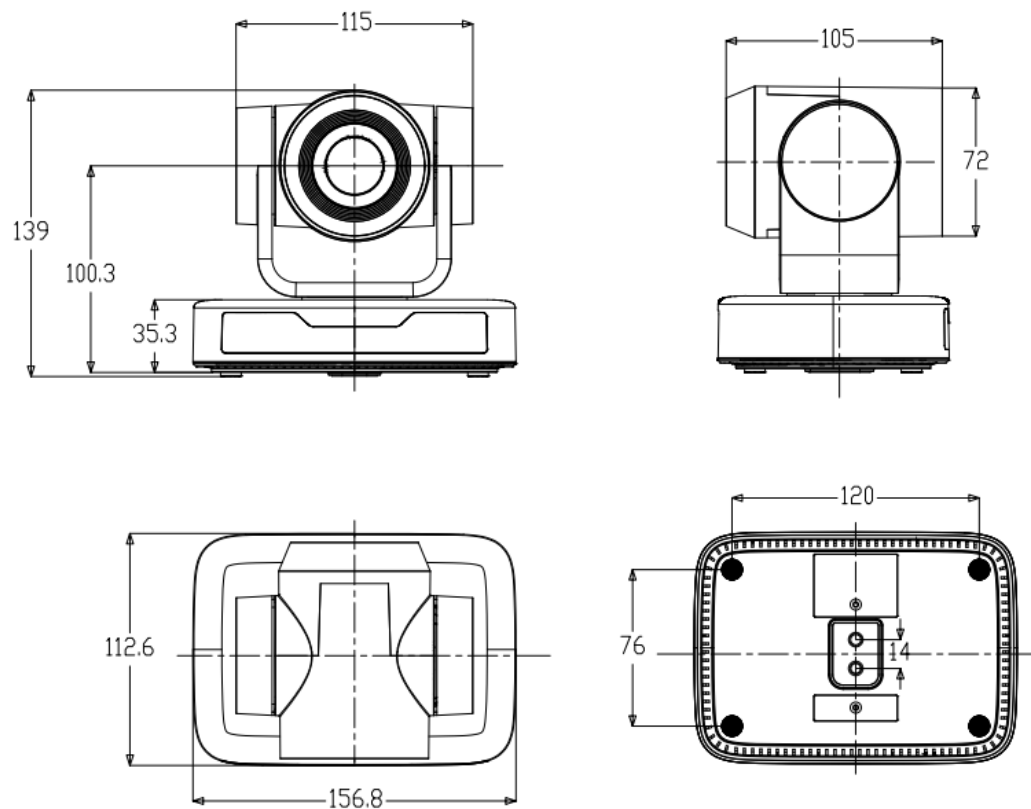

Figure 2.2 Product Dimension



## 2.1.3 Accessory

Please check below standard and optional accessories when unpacking the box.

Standard Accessory	Optional Accessory
Power adapter	Wall Mount
IR Remote Control	Ceiling Mount
RS232 Cable	
User Manual	
USB2.0 Cable	

USB2.0 video cable: If USB2.0 video cable is required for power supply without power adapter, in which power is supplied by red end and USB video signal is transmitted by black end; if power adapter is used, USB2.0 video cable is not required for power supply, and ordinary USB2.0 video cable is enough.

## 2.2 Main Features

This series camera has perfect functions, superior performance and rich video output interfaces; Featuring with advanced ISP processing algorithms, offering vivid and high resolution video with a strong sense of depth and fantastic color rendition.

- **Full HD Resolution:** 1/2.9 inch high quality CMOS sensor. Resolution is up to 1920x1080 with frame rate up to 30 fps.
- **Multiple Optical Zoom Lens:** 10X optical zoom lens.
- **Leading Auto Focus Technology:** Fast, accurate and stable auto focusing technology.
- **Low Noise and High SNR:** Super high SNR image is achieved with low noise CMOS. Advanced 2D/3D noise reduction technology further reduces the noise while ensuring high image clarity.
- **Control Interface:** RS485, RS232 (cascade connection)
- **Multiple Control Protocol:** Support VISCA, PELCO-D, PELCO-P protocols; Support automatic identification protocols.
- **Quiet Pan / Tilt Movement:** With high accuracy step driving motor, camera can pan / tilt extremely quiet and smooth.
- **Multiple presets:** Up to 255 presets (10 presets via remote control).
- **Multiple Application:** Online-education, Lecture Capture, Webcasting, Video conferencing, Tele-medicine, Unified Communication, Emergency command and control systems, etc.

## 2.3 Technical Parameter

Model	10X
<b>Camera Parameter</b>	
Sensor	1/2.9 inch high quality CMOS sensor
Effective Pixels	2.07 megapixel, 16: 9
Video Format	<b>H264/H265/MJPG:</b> 1920×1080P@30/25/20/15/10/5fps; 1280*720P@30/25/20/15/10/5fps; 960*540@30/25/20/15/10/5fps; 800*600@30/25/20/15/10/5fps; 720*576@30/25/20/15/10/5fps; 720*480@30/25/20/15/10/5fps; 640*480@30/25/20/15/10/5fps; 640*360@30/25/20/15/10/5fps; 352*288@30/25/20/15/10/5fps; 320*240@30/25/20/15/10/5fps; <b>YUY2:</b> 1280*720@10/5fps; 800*600@10/5fps; 640*480@30/25/20/15/10/5fps; 640*360@30/25/20/15/10/5fps; 320*180@30/25/20/15/10/5fps
View Angle	8.8° ~ 66°
Focus Length	f=4.34mm~41.66mm
AV	F1.85 – F2.43
Optical Zoom	10X
Digital Zoom	10X
Minimum Illumination	0.5Lux(F1.8, AGC ON)
DNR	2D & 3D DNR
White Balance	Auto / Manual/ One Push//3000K/3500K/4000K/4500K/5000K/5500K/6000K/6500K/7000K
Focus	Auto / Manual/ One Push Focus
Exposure	Auto / Manual
BLC	On/Off
Video Adjustment	Brightness, Color, Saturation, Contrast, Sharpness, B/W mode, Gamma curve
SNR	>50dB

<b>Input/output Interface</b>	
Video Output	USB2.0 Interface, A Type Interface
Video Compression Format	MJPG, H.264, H.265
Control Interface	RS232 (IN/OUT), RS485
Control Protocol	VISCA/Pelco-D/Pelco-P
Power Interface	HEC3800 outlet (DC12V)

<b>USB Feature</b>	
Operation Systems	Windows 7, Windows8, Windows10, Mac osx, Linux, etc
Video Compression Format	MJPG/H264/H265
USB Communication Protocol	UVC

<b>PTZ Parameter</b>	
Pan Rotation	-170°~+170°
Tilt Rotation	-30°~+30°
Pan Control Speed	0.1 ~60°/sec
Tilt Control Speed	0.1~40°/sec
Preset Speed	Pan: 60°/sec, Tilt: 40°/sec
Preset Number	255 presets (10 presets via remote control)

Other Parameter	
Input Voltage	12V
Input Current	Maximum: 4.98A
Power Consumption	Maximum: 2.5W
Stored Temperature	-40°C ~ +70°C
Storage Humidity	20% ~ 90%
Working Temperature	-10°C ~ +50°C
Working Humidity	20% ~ 80%
Dimension (W*H*D)	156.8mm×112.6mm×139.5mm
Weight	1KG
Application	Indoor
Package	Power Supply, RS232 Control Cable, IR Remote Control, User Manual, Warranty Card, USB2.0 Cable
Optional Accessories	Ceiling / Wall Mount (Extra Cost)

## 2.4 Interface Instruction

### 2.4.1 External Interface

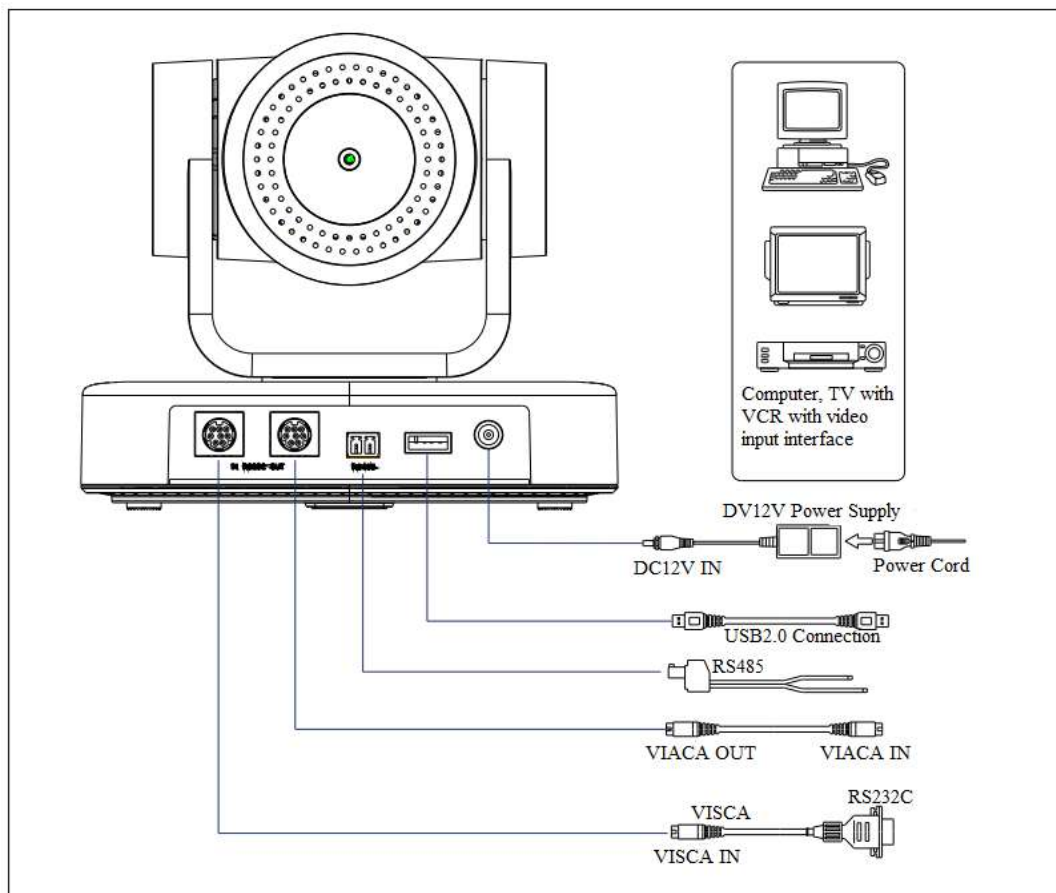
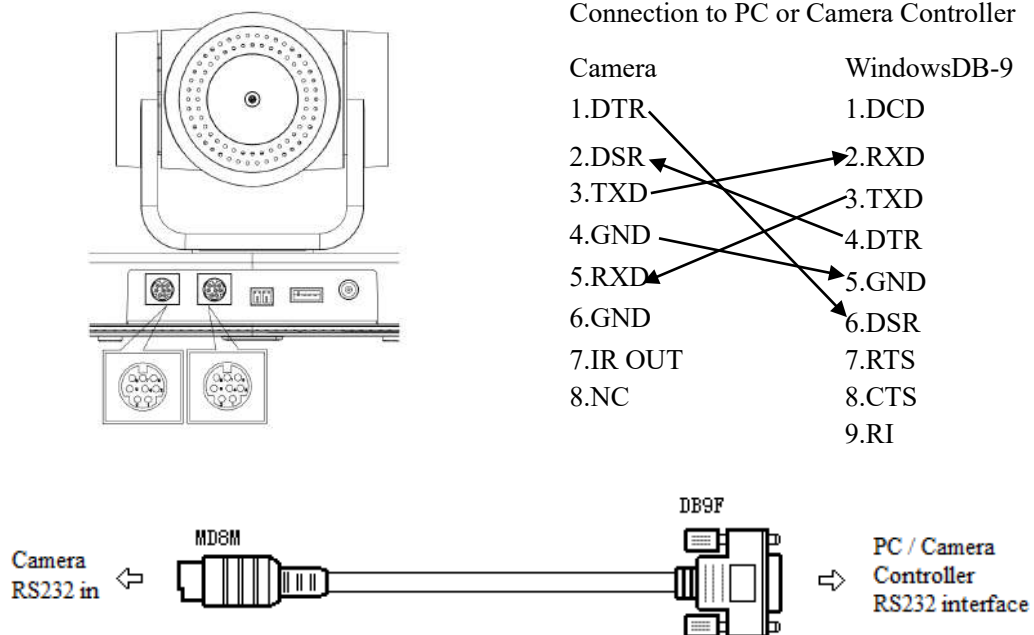

Figure2.4 Wiring Diagram

## 2.4.2 RS-232 Interface

### 1) RS-232 Interface Definition



### 2) RS-232 Mini-DIN 8-pin Port Definition

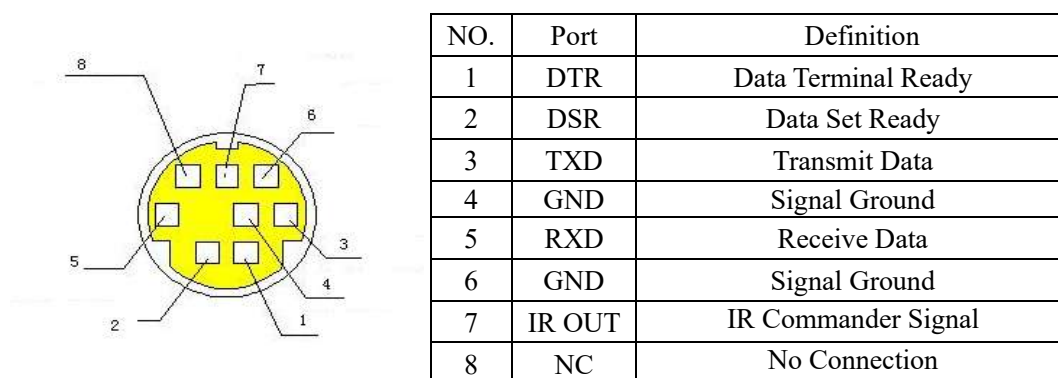

### 3) RS232(DB9) Port Definition

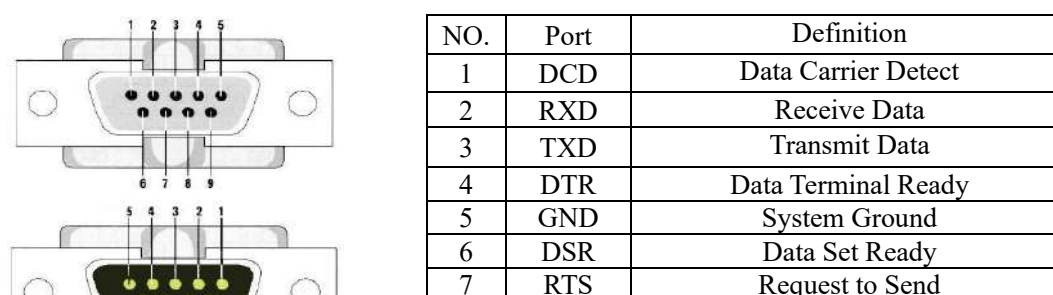

8	CTS	Clear to Send
9	RI	Ring Indicator

4) VISCA networking as shown below

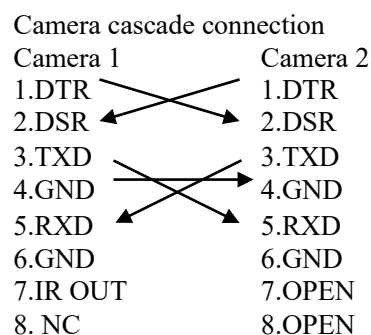
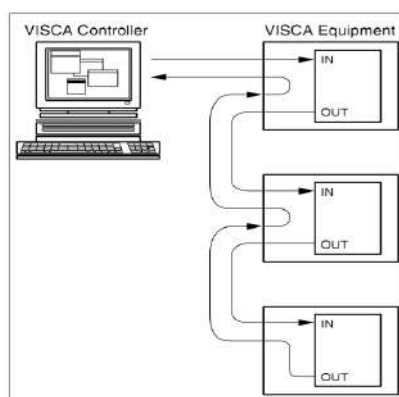

## 3. Application Instruction

### 3.1 Video Output

#### 3.1.1 Power-On Initial Configuration

The remote control receiving indicator flashes after power on, the pan-tilt turns left to the lowest left to the lowest, and then turns to the HOME position (both the horizontal and vertical positions are in the middle), while the movement first shrinks and then stretches. When remote control receiving indicator stops flashing, the self-checking is completed. After power on and self-checking, the camera will automatically return to the preset 0 position if it's pre-set.

#### 3.1.2 Video Output

Connect to the video output cable: the user can refer to Figure 1.1 product interfaces.

USB2.0 output: Connect the camera with the computer USB2.0 interface (black), open the Device Manager to see whether there is an imaging device and whether the Universal Serial Bus controllers recognize the USB2.0 device. After properly identified, open the software, choose the imaging device, and then it will output the image.

### 3.2 Remote Control

#### 3.2.1 Keys Introduction



- 1) In this manual, “press the key” means a click rather than a long-press, and a special note will be given if a long-press for more than one second is required.
- 2) When a key-combination is required, do it in sequence. For example, “【\*】+【#】+【F1】” means press “【\*】” first and then press “【#】” and last press “【F1】”.

### 1. Standby Key

The camera enters standby mode if long press 3s on standby key;

Long press 3s again on the standby key, the camera will self-check again and return to HOME position (If preset 0 position is set, the camera will return to preset 0 position).

### 2. Camera Selection



Select the camera address to control.

### 3. Focus Control



Auto: auto focus mode

Manual: manual focus mode

Focus + (near): Press 【FOCUS +】 key (Valid only in manual focus mode)

Focus - (far): Press 【FOCUS -】 key (Valid only in manual focus mode)

Press and hold the keys, the action of focus will keep continue and stop as soon as the key is released.

### 4. Zoom Control

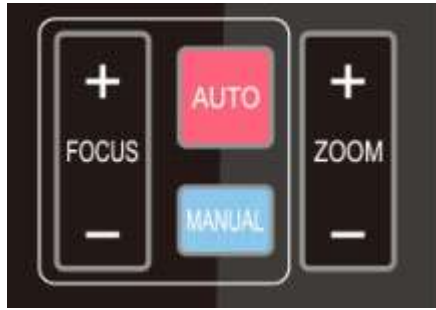

ZOOM +: press **【ZOOM +】** key to zoom in  
 ZOOM - : press **【ZOOM -】** key to zoom out  
 Press and hold the keys, the action of focus will keep continue and stop as soon as the key is released.

### 5. Set and Clear Presets



**Set Preset:** press **【SET PRESET】** button, and then press the number key 0-9 to set preset positions.

**Note: 10 presets via remote control.**

**Call Preset:** Press a number key 0-9 directly to call a preset position.

**Clear Preset:** press **【CLEAR PRESET】** button, and then press the number key 0-9 to clear preset positions.

**Note :** press the **【#】** key three times continually to clear all presets.



### 6. Pan/Tilt Control



Up: press ▲                      Down: press ▼  
 Left: press ◀                     Right: press ▶  
 Back to middle position: press“ **【HOME】** ”

Press and hold the up/down/left/right key, the pan/tilt movements will keep running, from slow to fast, until it runs to the endpoint; stop as soon as the key is released.

### 7. Menu Setting



- 【MENU】 : Open / close the OSD menu
- 【HOME】 : Camera lens back to the middle position;  
Confirm button; Enter next menu
- 【↑】【↓】: Choose item
- 【←】【→】: Modify values
- 【BLC ON/OFF】: Turn on or off the back light compensation

### 8. Camera Remote Control Address Setting



- 【\*】 + 【#】 + 【F1】 :Camera Address No.1
- 【\*】 + 【#】 + 【F2】 :Camera Address No. 2
- 【\*】 + 【#】 + 【F3】 :Camera Address No. 3
- 【\*】 + 【#】 + 【F4】 :Camera Address No. 4

## 3.3 Menu Introduction

### 3.3.1 Main Menu

In normal working mode, press 【MENU】 key to display the menu, using scroll arrow to point at or highlight the selected items.

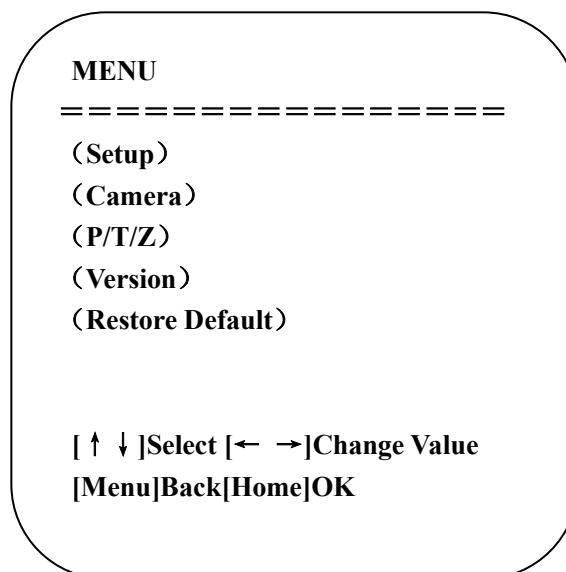

**Setup:** System parameter setting

**Camera:** Camera parameter setting

**P/T/Z:** Enter into sub menu

**Version:** Enter into sub menu

**Restore Default:** Enter into reset setting, select YES or NO to confirm



[↑↓] **Select**: For selecting menu  
 [← →] **Change Value**: For modifying parameters  
 [MENU] **Back**: Press [Menu] to return  
 [Home] **OK**: Press [Home] to confirm

### 3.3.2 System Setting

Move the pointer to the (Setup) in the Main Menu, click the **【HOME】** key and enter into the (System Setting) as shown below,

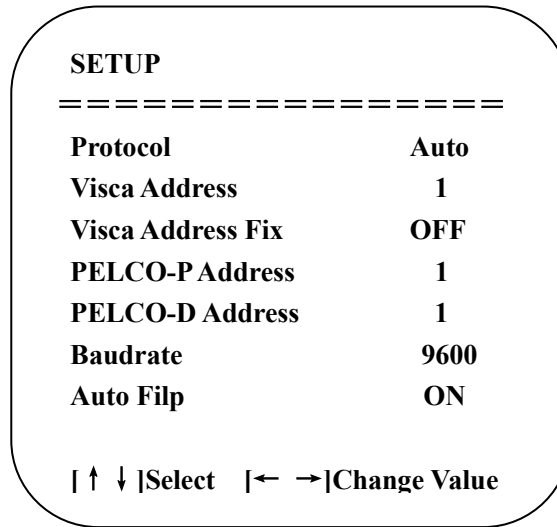

**Protocol**: VISCA/Pelco-P/Pelco-D/Auto  
**Visca Address**: VISCA=1~7 Pelco-P=1~255 Pelco-D=1~255  
**Baudrate**: 2400/4800/9600/115200  
**Visca Address Fix**: On/Off  
**Auto Filp**: On/Off

### 3.3.3 Camera Setting

Move the pointer to the (CAMERA) in the Main Menu, click the **【HOME】** key and enter the (CAMERA) as follow,

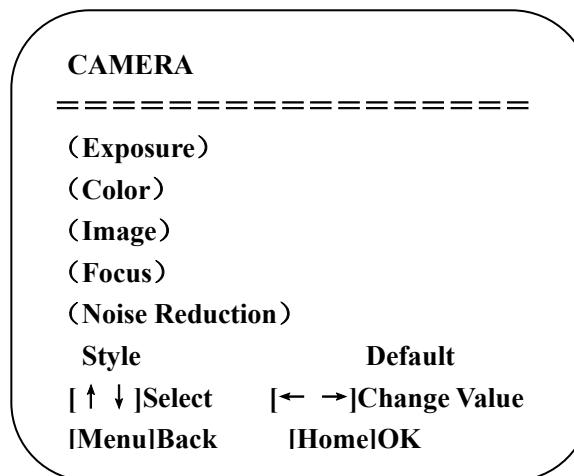

**Exposure**: Enter into Exposure setting

**Color:** Enter into color setting  
**Image:** Enter into image setting  
**Focus:** Enter into focus setting  
**Noise Reduction:** Enter into noise reduction

## 1) Exposure Setting

Move the pointer to the (EXPOSURE) in the Main Menu, click the **【HOME】** key and enter into the (Exposure sub menu) as shown below,

EXPOSURE	
Mode	Auto
EV	OFF
BLC	OFF
Flicker	50Hz
G.Limit	3
DRC	2
[ ↑ ↓ ]Select    [ ← → ]Change Value	
[Menu]Back	

**Mode:** Auto, Manual, Shutter priority, Iris priority and Brightness priority.

**EV:** On/Off (only available in auto mode)

**Compensation Level:** -7~7 (only available in auto mode when EV is ON)

**BLC:** ON/OFF for options (only available in auto mode)

**Dynamic Range:** 1~8, close

**Anti-Flicker:** OFF/50Hz/60Hz for options (only available in Auto/Iris priority/Brightness priority modes)

**Gain limit:** 0~15 (only available in Auto/ Iris priority /Brightness priority mode)

**WDR:** Off, 1~8

**ShutterPriority:** 1/25, 1/30, 1/50, 1/60, 1/90, 1/100, 1/120, 1/180, 1/250, 1/350, 1/500, 1/1000, 1/2000, 1/3000, 1/4000, 1/6000, 1/10000 (only available in Manual and Shutter priority mode)

**IRIS Priority:** OFF, F11.0, F9.6, F8.0, F6.8, F5.6, F4.8, F4.0, F3.4, F2.8, F2.4, F2.0, F1.8 (only available in Manual and Iris priority mode)

**Brightness:** 0~23 (only available in Brightness priority mode)

## 2) Color

Move the pointer to the (COLOR) in the Main Menu, click the **【HOME】** and enter the (COLOR sub menu) as follow,

COLOR	
=====	
<b>WB Mode</b>	<b>Auto</b>
<b>RG Tuning</b>	<b>-10</b>
<b>BG Tuning</b>	<b>-10</b>
<b>Saturation</b>	<b>100%</b>
<b>Hue</b>	<b>7</b>
<b>AWB Sensitivity</b>	<b>High</b>
[ ↑ ↓ ]Select [ ← → ]Change Value	
[Menu]Back	

**WB Mode:** Auto, Manual, One Push, 3000K, 3500K, 4000K, 4500K, 5000K, 5500K, 6000K, 6500K, 7000K

**Saturation:** 60%, 70%, 80%, 90%, 100%, 110%, 120%, 130%, 140%, 150%, 160%, 170%, 180%, 190%, 200%

**Red fine-tuning:** -10~10 (only available in automatic mode)

**Blue fine-tunable:** -10~10 (only available in automatic mode)

**RED GAIN:** 0~255(only available in Manual mode)

**BLUE GAIN:** 0~255(only available in Manual mode)

**AWB Sensitivity:** high/middle/low

**Chroma:** 0~14

### 3) Image

Move the pointer to the (IMAGE) in the Menu, click the【HOME】and enter into the (IMAGE sub menu) as follow,

IMAGE	
=====	
<b>Brightness</b>	<b>7</b>
<b>Contrast</b>	<b>8</b>
<b>Sharpness</b>	<b>3</b>
<b>Flip-H</b>	<b>OFF</b>
<b>Flip-V</b>	<b>OFF</b>
<b>B&amp;W-Mode</b>	<b>Color</b>
<b>Gamma</b>	<b>Default</b>
<b>DCI</b>	<b>Close</b>
<b>Low-Light Mode</b>	<b>OFF</b>
[ ↑ ↓ ]Select [ ← → ]Change Value	
[Menu]Back	

**Brightness:** 0~14

**Contrast:** 0~14

**Sharpness:** 0~15

**Flip-H:** On/Off

**Flip-V:** On/Off

**B&W Mode:** color, black/white

**Gamma:** Default/0.45/0.50/0.5/0.63

**DCI:** Dynamic Contrast: Off/1~8

**Minimum Illumination:** On/Off

#### 4) Focus

Move the pointer to the (FOCUS) in the Menu, click the **【HOME】** and enter the (FOCUS) as follow,

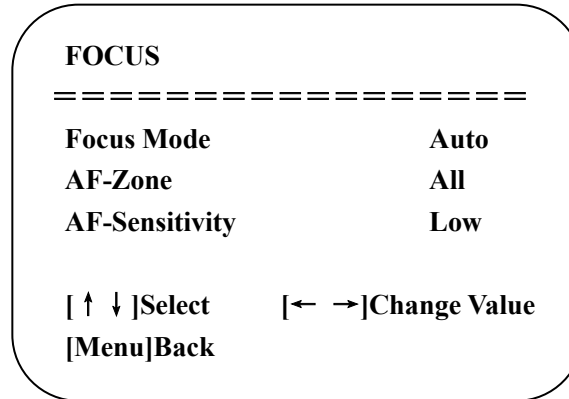

**Focus Mode:** Auto/manual

**AF-Zone:** Up/middle/down

**AF-Sensitivity:** High/middle/low

#### 5) Noise Reduction

Move the pointer to the (NOISE REDUCTION) in the Menu, click the **【HOME】** and enter the (NOISE REDUCTION) as follow,

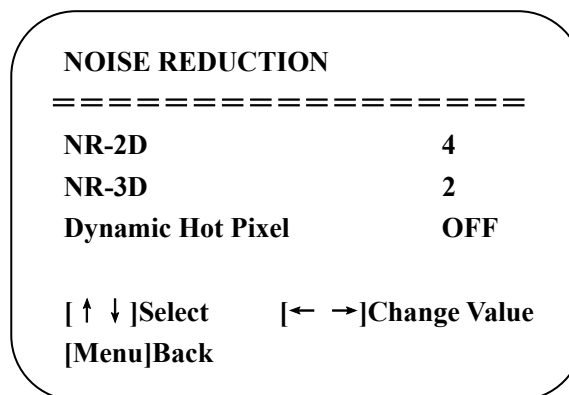

**2D Noise Reduction:** Auto, close, 1~7

**3D Noise Reduction:** Close, 1~8

**Dynamic Hot Pixel:** Close, 1~5

### 3.3.4 P/T/Z

Move the pointer to the (P/T/Z) in the Main Menu, click the **【HOME】** and enter the (P/T/Z) as follow,

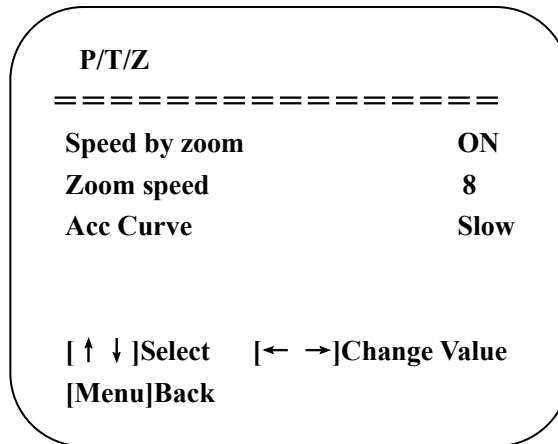

**Depth of Field:** Only effective for the remote controller, On/ Off;  
(When zooming in, the PT control speed by remoter will become slow)  
**Zoom Speed:** Set the zoom speed for the remote controller, 1~8  
**Image Freezing:** On/Off  
**Accelerating Curve:** Fast/Slow

### 3.3.5 Version

Move the pointer to the (VERSION) in the Main Menu, click the **【HOME】** and enter the (VERSION) as follow,

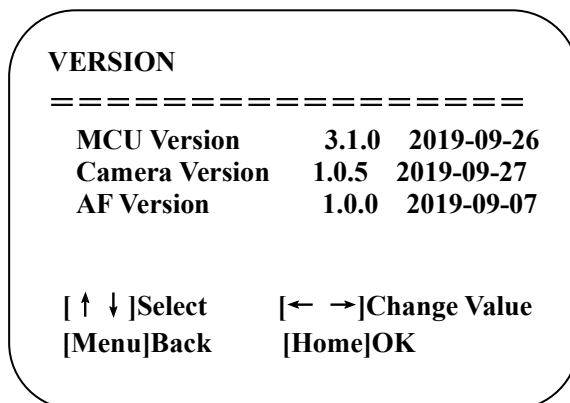

**MCU Version:** Display MCU version information  
**Camera Version:** Display camera version information  
**AF Version:** Display the focus version information

### 3.3.6 Restore Default

Move the pointer to the (RESTORE DEFAULT) in the Main Menu, click the **【HOME】** and enter the (RESTORE DEFAULT) as follow,

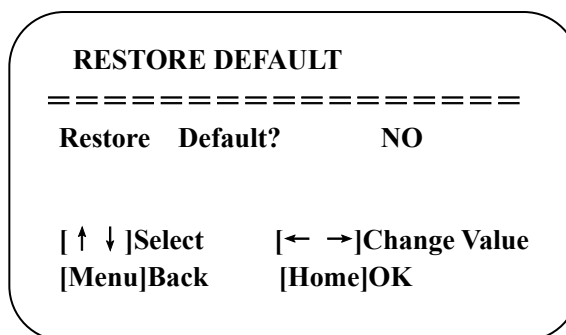

Restore default: YES/NO. Color style and video format cannot be restored to factory default

**Note: If the address of former remoter is not 1 but another one from 2, 3, 4, the corresponding camera address will restore to 1 when all parameters or system parameters are restored. User should change the remoter address to be 1 (press No.1 according to the camera so to get normal operation).**

## 4. Serial Port Communication and Control

The camera could be controlled through RS232/RS485 interface; RS232C serial parameter are as follows:  
Baud rate: 2400/4800/9600/115200 bits / sec; Start bit: 1; data bits: 8; Stop bit: 1; Parity: None.

After power on, the camera first goes left, then back to the middle position. Self-test is finished after the zoom moved to the farthest and then back to the nearest position. If the camera saved 0 preset before, it will be back to that position after initialization. At this point, the user can control the camera by the serial commands.

### 4.1 VISCA Protocol list

#### 4.1.1 VISCA Protocol Return Command

Ack/Completion Message		
	Command packet	Note
ACK	z0 41 FF	Returned when the command is accepted.
Completion	z0 51 FF	Returned when the command has been executed.
z = camera address + 8		
Error Messages		
	Command packet	Note
Syntax Error	z0 60 02 FF	Returned when the command format is different or when a command with illegal command parameters is accepted
Command Not Executable	z0 61 41 FF	Returned when a command cannot be executed due to current conditions. For example, when commands controlling the focus manually are received during auto focus.

## 4.1.2 VISCA Protocol Control Command

Command	Function	Command packet	Note
AddressSet	Broadcast	88 30 0p FF	p: Address setting
IF_Clear	Broadcast	88 01 00 01 FF	I/F Clear
CommandCancel		8x 21 FF	
CAM_Power	On	8x 01 04 00 02 FF	Power ON/OFF
	Off	8x 01 04 00 03 FF	
CAM_Zoom	Stop	8x 01 04 07 00 FF	p = 0(low) - F(high) pqrs: Zoom Position
	Tele(Standard)	8x 01 04 07 02 FF	
	Wide(Standard)	8x 01 04 07 03 FF	
	Tele(Variable)	8x 01 04 07 2p FF	
	Wide(Variable)	8x 01 04 07 3p FF	
	Direct	8x 01 04 47 0p 0q 0r 0s FF	
CAM_Focus	Stop	8x 01 04 08 00 FF	p = 0(low) - F(high) pqrs: Focus Position
	Far(Standard)	8x 01 04 08 02 FF	
	Near(Standard)	8x 01 04 08 03 FF	
	Far(Variable)	8x 01 04 08 2p FF	
	Near (Variable)	8x 01 04 08 3p FF	
	Direct	8x 01 04 48 0p 0q 0r 0s FF	
	Auto Focus	8x 01 04 38 02 FF	
	Manual Focus	8x 01 04 38 03 FF	
	One Push mode	8x 01 04 38 04 FF	
CAM_Zoom Focus	Direct	8x 01 04 47 0p 0q 0r 0s 0t 0u 0v 0w FF	pqrs: Zoom Position tuvw: Focus Position
CAM_WB	Auto	8x 01 04 35 00 FF	
	3000K	8x 01 04 35 01 FF	
	4000k	8x 01 04 35 02 FF	
	One Push mode	8x 01 04 35 03 FF	
	5000k	8x 01 04 35 04 FF	
	Manual	8x 01 04 35 05 FF	
	6500k	8x 01 04 35 06 FF	
	3500K	8x 01 04 35 07 FF	
	4500K	8x 01 04 35 08 FF	
	5500K	8x 01 04 35 09 FF	
	6000K	8x 01 04 35 0A FF	
	7000K	8x 01 04 35 0B FF	
CAM_RGain	Reset	8x 01 04 03 00 FF	Manual Control of R Gain pq: R Gain
	Up	8x 01 04 03 02 FF	
	Down	8x 01 04 03 03 FF	
	Direct	8x 01 04 43 00 00 0p 0q FF	
CAM_Bgain	Reset	8x 01 04 04 00 FF	Manual Control of B Gain pq: B Gain
	Up	8x 01 04 04 02 FF	
	Down	8x 01 04 04 03 FF	
	Direct	8x 01 04 44 00 00 0p 0q FF	
CAM_AE	Full Auto	8x 01 04 39 00 FF	Automatic Exposure mode
	Manual	8x 01 04 39 03 FF	Manual Control mode

Command	Function	Command packet	Note
	Shutter priority	8x 01 04 39 0A FF	Shutter Priority Automatic Exposure mode
	Iris priority	8x 01 04 39 0B FF	Iris Priority Automatic Exposure mode
	Bright	8x 01 04 39 0D FF	Bright mode
CAM_Shutter	Reset	8x 01 04 0A 00 FF	Shutter Setting
	Up	8x 01 04 0A 02 FF	
	Down	8x 01 04 0A 03 FF	
	Direct	8x 01 04 4A 00 00 0p 0q FF	pq: Shutter Position
CAM_Iris	Reset	8x 01 04 0B 00 FF	Iris Setting
	Up	8x 01 04 0B 02 FF	
	Down	8x 01 04 0B 03 FF	
	Direct	8x 01 04 4B 00 00 0p 0q FF	pq: Iris Position
CAM_Gain Limit	Gain Limit	8x 01 04 2C 0p FF	p: Gain Positon
CAM_Bright	Reset	8x 01 04 0D 00 FF	Bright Setting
	Up	8x 01 04 0D 02 FF	
	Down	8x 01 04 0D 03 FF	
	Direct	8x 01 04 4D 00 00 0p 0q FF	pq: Bright Positon
CAM_ExpComp	On	8x 01 04 3E 02 FF	Exposure Compensation ON/OFF
	Off	8x 01 04 3E 03 FF	
	Reset	8x 01 04 0E 00 FF	Exposure Compensation Amount Setting
	Up	8x 01 04 0E 02 FF	
	Down	8x 01 04 0E 03 FF	
	Direct	8x 01 04 4E 00 00 0p 0q FF	pq: ExpComp Position
CAM_Back Light	On	8x 01 04 33 02 FF	Back Light Compensation
	Off	8x 01 04 33 03 FF	
CAM_WDRStrength	Reset	8x 01 04 21 00 FF	WDR Level Setting
	Up	8x 01 04 21 02 FF	
	Down	8x 01 04 21 03 FF	
	Direct	8x 01 04 51 00 00 00 0p FF	p: WDR Level Positon
CAM_NR (2D)		8x 01 04 53 0p FF	P=0-7 0:OFF
CAM_NR (3D)		8x 01 04 54 0p FF	P=0-8 0:OFF
CAM_Gamma		8x 01 04 5B 0p FF	p = 0 – 4 0: Default 1: 0.45 2: 0.50 3: 0.55 4: 0.63
CAM_Flicker	OFF	8x 01 04 23 00 FF	OFF
	50HZ	8x 01 04 23 01 FF	50HZ
	60HZ	8x 01 04 23 02 FF	60HZ
CAM_Aperture	Reset	8x 01 04 02 00 FF	Aperture Control
	Up	8x 01 04 02 02 FF	
	Down	8x 01 04 02 03 FF	
	Direct	8x 01 04 42 00 00 0p 0q FF	pq: Aperture Gain
CAM_Memory	Reset	8x 01 04 3F 00 pq FF	pq: Memory Number(=0 to 254) Corresponds to 0 to 9 on the Remote Commander
	Set	8x 01 04 3F 01 pq FF	
	Recall	8x 01 04 3F 02 pq FF	
CAM_LR_Reverse	On	8x 01 04 61 02 FF	Image Flip Horizontal ON/OFF
	Off	8x 01 04 61 03 FF	
CAM_PictureFlip	On	8x 01 04 66 02 FF	Image Flip Vertical ON/OFF
	Off	8x 01 04 66 03 FF	



Command	Function	Command packet	Note
CAM_ColorSaturation	Direct	8x 01 04 49 00 00 00 0p FF	P=0-E 0:60% 1:70% 2:80% 3:90% 4:100% 5:110% 6:120% 7:130% 8:140% 9:150% 10:160% 11:160% 12:180% 13:190% 14:200%
CAM_IDWrite		8x 01 04 22 0p 0q 0r 0s FF	pqrs: Camera ID (=0000 to FFFF)
SYS_Menu	ON	8x 01 04 06 06 02 FF	Turn on the menu screen
	OFF	8x 01 04 06 06 03 FF	Turn off the menu screen
IR_Receive	ON	8x 01 06 08 02 FF	IR(remote commander)receive On/Off
	OFF	8x 01 06 08 03 FF	
IR_ReceiveReturn	On	8x 01 7D 01 03 00 00 FF	IR(remote commander)receive message via the VISCA communication ON/OFF
	Off	8x 01 7D 01 13 00 00 FF	
CAM_SettingReset	Reset	8x 01 04 A0 10 FF	Reset Factory Setting
CAM_Brightness	Direct	8x 01 04 A1 00 00 0p 0q FF	pq: Brightness Position
CAM_Contrast	Direct	8x 01 04 A2 00 00 0p 0q FF	pq: Contrast Position
CAM_Flip	OFF	8x 01 04 A4 00 FF	Single Command For Video Flip
	Flip-H	8x 01 04 A4 01 FF	
	Flip-V	8x 01 04 A4 02 FF	
	Flip-HV	8x 01 04 A4 03 FF	
CAM_VideoSystem	Set camera video system	8x 01 06 35 00 0p FF	P: 0~E Video format 0:1080P60 8:720P30 1:1080P50 9:720P25 2:1080i60 A: 1080P59.94 3:1080i50 B: 1080i59.94 4:720P60 C: 720P59.94 5:720P50 D: 1080P29.97 6:1080P30 E: 720P29.97 7:1080P25
Pan_tiltDrive	Up	8x 01 06 01 VV WW 03 01 FF	VV: Pan speed 0x01 (low speed) to 0x18 (high speed) WW: Tilt speed 0x01 (low speed) to 0x14 (high speed) YYYY: Pan Position ZZZZ: Tilt Position
	Down	8x 01 06 01 VV WW 03 02 FF	
	Left	8x 01 06 01 VV WW 01 03 FF	
	Right	8x 01 06 01 VV WW 02 03 FF	
	Upleft	8x 01 06 01 VV WW 01 01 FF	
	Upright	8x 01 06 01 VV WW 02 01 FF	
	DownLeft	8x 01 06 01 VV WW 01 02 FF	
	DownRight	8x 01 06 01 VV WW 02 02 FF	
	Stop	8x 01 06 01 VV WW 03 03 FF	
	AbsolutePosition	8x 01 06 02 VV WW 0Y 0Y 0Y 0Y 0Z 0Z 0Z 0Z FF	
	RelativePosition	8x 01 06 03 VV WW 0Y 0Y 0Y 0Y 0Z 0Z 0Z 0Z FF	
	Home	8x 01 06 04 FF	
	Reset	8x 01 06 05 FF	
Pan-tiltLimitSet	Set	8x 01 06 07 00 0W 0Y 0Y 0Y 0Y 0Z 0Z 0Z 0Z FF	W:1 UpRight 0:DownLeft YYYY: Pan Limit Position(TBD) ZZZZ: Tilt Limit Position(TBD)
	Clear	8x 01 06 07 01 0W 07 0F 0F 0F 07 0F 0F 0F FF	

### 4.1.3 VISCA Protocol Inquiry Command

Command	Command Packet	Return Packet	Note
CAM_PowerInq	8x 09 04 00 FF	y0 50 02 FF	On
		y0 50 03 FF	Off(Standby)
CAM_ZoomPosInq	8x 09 04 47 FF	y0 50 0p 0q 0r 0s FF	pqrs: Zoom Position
CAM_FocusAFModeInq	8x 09 04 38 FF	y0 50 02 FF	Auto Focus

		y0 50 03 FF	Manual Focus
		y0 50 04 FF	One Push mode
CAM_FocusPosInq	8x 09 04 48 FF	y0 50 0p 0q 0r 0s FF	pqrs: Focus Position
CAM_WBModeInq	8x 09 04 35 FF	y0 50 00 FF	Auto
		y0 50 01 FF	3000K
		y0 50 02 FF	4000K
		y0 50 03 FF	One Push Mode
		y0 50 04 FF	5000K
		y0 50 05 FF	Manual
		y0 50 06 FF	6500K
		y0 50 06 FF	6500K
		y0 50 07 FF	3500K
		y0 50 08 FF	4500K
		y0 50 09 FF	5500K
		y0 50 0A FF	6000K
CAM_RGainInq	8x 09 04 43 FF	y0 50 0B FF	7000K
CAM_BGainInq	8x 09 04 44 FF	y0 50 00 00 0p 0q FF	pq: B Gain
CAM_AEModeInq	8x 09 04 39 FF	y0 50 00 FF	Full Auto
		y0 50 03 FF	Manual
		y0 50 0A FF	Shutter priority
		y0 50 0B FF	Iris priority
		y0 50 0D FF	Bright
CAM_ShutterPosInq	8x 09 04 4A FF	y0 50 00 00 0p 0q FF	pq: Shutter Position
CAM_IrisPosInq	8x 09 04 4B FF	y0 50 00 00 0p 0q FF	pq: Iris Position
CAM_GainLimitInq	8x 09 04 2C FF	y0 50 0p FF	p: Gain Positon
CAM_BrightPosInq	8x 09 04 4D FF	y0 50 00 00 0p 0q FF	pq: Bright Position
CAM_ExpCompModeInq	8x 09 04 3E FF	y0 50 02 FF	On
		y0 50 03 FF	Off
CAM_ExpCompPosInq	8x 09 04 4E FF	y0 50 00 00 0p 0q FF	pq: ExpComp Position
CAM_BacklightModeInq	8x 09 04 33 FF	y0 50 02 FF	On
		y0 50 03 FF	Off
CAM_WDRStrengthInq	8x 09 04 51 FF	y0 50 00 00 00 0p FF	p: WDR Strength
CAM_NRLevel(2D) Inq	8x 09 04 53 FF	y0 50 0p FF	P: 2DNRLLevel
CAM_NRLevel(3D) Inq	8x 09 04 54 FF	y0 50 0p FF	P:3D NRLevel
CAM_FlickerModeInq	8x 09 04 55 FF	y0 50 0p FF	p: Flicker Settings(0: OFF, 1: 50Hz, 2:60Hz)
CAM_ApertureInq	8x 09 04 42 FF	y0 50 00 00 0p 0q FF	pq: Aperture Gain
CAM_PictureEffectModeInq	8x 09 04 63 FF	y0 50 00 FF	Off
		y0 50 04 FF	B&W
CAM_MemoryInq	8x 09 04 3F FF	y0 50 0p FF	p: Memory number last operated.
SYS_MenuModeInq	8x 09 06 06 FF	y0 50 02 FF	On
		y0 50 03 FF	Off
CAM_LR_ReverseInq	8x 09 04 61 FF	y0 50 02 FF	On
		y0 50 03 FF	Off
CAM_PictureFlipInq	8x 09 04 66 FF	y0 50 02 FF	On
		y0 50 03 FF	Off
CAM_ColorSaturationInq	8x 09 04 49 FF	y0 50 00 00 00 0p FF	p: Color Gain setting 0h (60%) to Eh (130%)
CAM_IDInq	8x 09 04 22 FF	y0 50 0p FF	p: Gamma ID
IR_ReceiveInq	8x 09 06 08 FF	y0 50 02 FF	On
		y0 50 03 FF	Off
IR_ReceiveReturn		y0 07 7D 01 04 00 FF	Power ON/OFF
		y0 07 7D 01 04 07 FF	Zoom tele/wide
		y0 07 7D 01 04 38 FF	AF ON/OFF
		y0 07 7D 01 04 33 FF	Camera Backlight
		y0 07 7D 01 04 3F FF	Camera Memery
		y0 07 7D 01 06 01 FF	Pan titleDriver
CAM_BrightnessInq	8x 09 04 A1 FF	y0 50 00 00 0p 0q FF	pq: Brightness Position
CAM_ContrastInq	8x 09 04 A2 FF	y0 50 00 00 0p 0q FF	pq: Contrast Position
CAM_FlipInq	8x 09 04 A4 FF	y0 50 00 FF	Off
		y0 50 01 FF	Flip-H
		y0 50 02 FF	Flip-V
		y0 50 03 FF	Flip-HV

CAM_GammaInq	8x 09 04 5B FF	y0 50 0p FF	p: Gamma setting
CAM_VersionInq	8x 09 00 02 FF	y0 50 ab cd mn pq rs tu vw FF	ab cd : vender ID ( 0220 ) mn pq : model ID ST ( 0510 ) 、 U2 ( 0512 )、 U3 ( 0513 ) rs tu : ARM Version vw : reserve
VideoSystemInq	8x 09 06 23 FF	y0 50 0p FF	P: 0~E Video format 0:1080P60 8:720P30 1:1080P50 9:720P25 2:1080i60 A: 1080P59.94 3:1080i50 B: 1080i59.94 4:720P60 C: 720P59.94 5:720P50 D: 1080P29.97 6:1080P30 E: 720P29.97 7:1080P25
Pan-tiltMaxSpeedInq	8x 09 06 11 FF	y0 50 ww zz FF	ww: Pan Max Speed zz: Tilt Max Speed
Pan-tiltPosInq	8x 09 06 12 FF	y0 50 0w 0w 0w 0w 0z 0z 0z 0z FF	www: Pan Position zzzz: Tilt Position

**Note:**[X] in the above table indicates the camera address to be operated, **【y】 = 【x + 8】** .

## 4.2 Pelco-D Protocol Command List

Function	Byte1	Byte2	Byte3	Byte4	Byte5	Byte6	Byte7
Up	0xFF	Address	0x00	0x08	Pan Speed	Tilt Speed	SUM
Down	0xFF	Address	0x00	0x10	Pan Speed	Tilt Speed	SUM
Left	0xFF	Address	0x00	0x04	Pan Speed	Tilt Speed	SUM
Right	0xFF	Address	0x00	0x02	Pan Speed	Tilt Speed	SUM
Upleft	0xFF	Address	0x00	0x0C	Pan Speed	Tilt Speed	SUM
Upright	0xFF	Address	0x00	0x0A	Pan Speed	Tilt Speed	SUM
DownLeft	0xFF	Address	0x00	0x14	Pan Speed	Tilt Speed	SUM
DownRight	0xFF	Address	0x00	0x12	Pan Speed	Tilt Speed	SUM
Zoom In	0xFF	Address	0x00	0x20	0x00	0x00	SUM
Zoom Out	0xFF	Address	0x00	0x40	0x00	0x00	SUM
Focus Far	0xFF	Address	0x00	0x80	0x00	0x00	SUM
Focus Near	0xFF	Address	0x01	0x00	0x00	0x00	SUM
Stop	0xFF	Address	0x00	0x00	0x00	0x00	SUM
Set Preset	0xFF	Address	0x00	0x03	0x00	Preset ID	SUM
Clear Preset	0xFF	Address	0x00	0x05	0x00	Preset ID	SUM
Call Preset	0xFF	Address	0x00	0x07	0x00	Preset ID	SUM
Query Pan Position	0xFF	Address	0x00	0x51	0x00	0x00	SUM
Query Pan Position Response	0xFF	Address	0x00	0x59	Value High Byte	Value Low Byte	SUM
Query Tilt Position	0xFF	Address	0x00	0x53	0x00	0x00	SUM
Query Tilt Position Response	0xFF	Address	0x00	0x5B	Value High Byte	Value Low Byte	SUM

Query Zoom Position	0xFF	Address	0x00	0x55	0x00	0x00	SUM
Query Zoom Position Response	0xFF	Address	0x00	0x5D	Value High Byte	Value Low Byte	SUM

### 4.3 Pelco-P Protocol Command List

Function	Byte1	Byte2	Byte3	Byte4	Byte5	Byte6	Byte7	Byte8
Up	0xA0	Address	0x00	0x08	Pan Speed	Tilt Speed	0xAF	XOR
Down	0xA0	Address	0x00	0x10	Pan Speed	Tilt Speed	0xAF	XOR
Left	0xA0	Address	0x00	0x04	Pan Speed	Tilt Speed	0xAF	XOR
Right	0xA0	Address	0x00	0x02	Pan Speed	Tilt Speed	0xAF	XOR
Upleft	0xA0	Address	0x00	0x0C	Pan Speed	Tilt Speed	0xAF	XOR
Upright	0xA0	Address	0x00	0x0A	Pan Speed	Tilt Speed	0xAF	XOR
DownLeft	0xA0	Address	0x00	0x14	Pan Speed	Tilt Speed	0xAF	XOR
DownRight	0xA0	Address	0x00	0x12	Pan Speed	Tilt Speed	0xAF	XOR
Zoom In	0xA0	Address	0x00	0x20	0x00	0x00	0xAF	XOR
Zoom Out	0xA0	Address	0x00	0x40	0x00	0x00	0xAF	XOR
Stop	0xA0	Address	0x00	0x00	0x00	0x00	0xAF	XOR
Focus Far	0xA0	Address	0x01	0x00	0x00	0x00	0xAF	XOR
Focus Near	0xA0	Address	0x02	0x00	0x00	0x00	0xAF	XOR
Set Preset	0xA0	Address	0x00	0x03	0x00	Preset ID	0xAF	XOR
Clear Preset	0xA0	Address	0x00	0x05	0x00	Preset ID	0xAF	XOR
Call Preset	0xA0	Address	0x00	0x07	0x00	Preset ID	0xAF	XOR
Query Pan Position	0xA0	Address	0x00	0x51	0x00	0x00	0xAF	XOR
Query Pan Position Response	0xA0	Address	0x00	0x59	Value High Byte	Value Low Byte	0xAF	XOR
Query Tilt Position	0xA0	Address	0x00	0x53	0x00	0x00	0xAF	XOR
Query Tilt Position Response	0xA0	Address	0x00	0x5B	Value High Byte	Value Low Byte	0xAF	XOR
Query Zoom Position	0xA0	Address	0x00	0x55	0x00	0x00	0xAF	XOR
Query Zoom Position Response	0xA0	Address	0x00	0x5D	Value High Byte	Value Low Byte	0xAF	XOR

## 5. Maintenance and Troubleshooting

---

### 5.1 Camera Maintenance

- 1) Please power off the camera and disconnect the power adapter and socket, if it's not used for a long run.
- 2) Use soft cloth or tissue to clean the camera cover.
- 3) Wipe it with a soft, dry cloth when cleaning the camera lens. Wipe it gently with a mild detergent if needed. Do not use strong or corrosive detergents to avoid scratching the lens and affecting the video quality.

### 5.2 Troubleshooting

#### 1) No video output

- a. Check whether the camera power supply is connected, the voltage is normal, the power indicator is lit.
- b. Whether the machine could do self-check after restarted.
- c. Check whether the bottom of the DIP switch is the normal operating mode (see Table 2.2 and Table 2.3)
- d. Check whether the video output cable or video display is normal

#### 2) No image sometimes

- a. Check whether the video output cable or video display is normal

#### 3) Video dithering when zoom-in or zoom-out

- a. Check whether the camera installation position is solid
- b. Whether there is shaking machine or objects around the camera

#### 4) Remote control not works

- a. Remote control address is set to 1 (if the machine is set back to the factory defaults, remote control addresses need to be back to 1 too)
- b. Check whether the battery is installed on the remote controller or low.
- c. Check the camera working mode is the normal operating mode (see Table 2.2 and Table 2.3)
- d. Check the menu whether is closed, camera control through remote controller is only available after exiting the menu. If video output from LAN, menu will not be displayed, menu will automatically exists 30s later, and then it can be controlled by remote controller.

#### 5) Serial port not works

- a. Check whether the camera serial device protocol, baud rate, address is consistent
- b. Check whether the control cable is connected properly
- c. Check whether the camera working mode is the normal operating mode (see Table 2.2 and Table 2.3)